

7.2 Reactor Trip System—Instrumentation and Controls

7.2.1 Description

The reactor trip system for the Lungmen NPS design is called the Reactor Protection System (RPS), which is described in this section.

7.2.1.1 System Description

7.2.1.1.1 RPS Identification

The Reactor Protection System (RPS) is the overall complex of instrument channels, trip logics, trip actuators and scram logic circuitry that initiate rapid insertion of control rods (scram) to shut down the reactor. The RPS also establishes reactor operating modes and provides status and control signals to other systems and annunciators. To accomplish its overall function, the RPS interfaces with the Main Steam System, Containment Monitoring System, Multiplexing System, Safety System Logic and Control, Neutron Monitoring System, Control Rod Drive System, Rod and Control and Information System, Recirculation Flow Control System, Steam Bypass and Pressure Control System, Main Turbine System, Plant Computer System, Main Control Room Panels, Main Control Room Back Panels, Vital AC Power, Direct Current Power Supply, and the Raceway System.

7.2.1.1.2 RPS Classification

The RPS is classified as Safety Class 2, Seismic Category I, and Quality Group B (electric Safety Class 1E) per Regulatory Guide 1.26 and meet the requirements of 10CFR50.55a(h).

7.2.1.1.3 Power Sources

The RPS utilizes two types of power:

- (1) 120 V vital AC—taken from the four divisional SSLC power supply buses discussed in Section 8.3. Each bus supplies power for one division of RPS logic. Two of the four buses also provide 120 VAC power through the two divisions of RPS scram logic circuitry to the “A” and “B” solenoids of the scram hydraulic control units (HCUs) of the Control Rod Drive System.
- (2) 125 VDC—taken from two of the four divisional SSLC battery buses discussed in Section 8.3. Each bus provides 125 VDC power through one of the two divisions of RPS scram logic circuitry to the solenoid of one of the two air header dump valves of the Control Rod Drive System.

7.2.1.1.4 RPS Equipment Design

The RPS is designed to provide reliable single-failure-proof capability to automatically or manually initiate a reactor scram while maintaining protection against unnecessary scrams resulting from single failures. This is accomplished through the combination of fail-safe

equipment design and redundant two-out-of-four logic arrangement. All equipment supporting RPS is designed to fail into a trip initiating state on loss of power or input signal. In conjunction with this, trip initiating logic signals to and within the RPS are asserted low, whereas trip bypass logic signals and trip bypass permissive logic signals are asserted high.

7.2.1.1.4.1 General RPS/SSLC Equipment

The RPS equipment is divided into four redundant instrument channels (channel of sensors), four divisions of trip logics, four division of trip logics, four divisions of trip actuators, and two divisions of manual scram controls and scram logic circuitry. The instrument channels, divisions of trip logics, divisions of trip actuators and associated portions of the division of scram logic circuitry together constitute the RPS scram and backup scram automatic initiation logic. The divisions of manual scram controls and associated portions of the division of scram logic circuitry together constitute the RPS scram and backup scram manual initiation logic. The automatic and manual scram initiation logics are independent of each other. RPS equipment is shown in Figure 7.2-1.

(1) Instrument channels (channels of sensors)

Equipment within a sensor channel includes sensors (transducers or switches), multiplexers and digital trip modules (DTMs). The sensors within each channel monitor plant variables (Subsection 7.2.1.1.4.2) send either analog or discrete output to remote multiplexer units (RMUs) within the associated division of EMS. Each division of the EMS performs analog-to-digital conversion on analog signals and sends the digital or digitized analog output values of all monitored variables to the SSLC DTM within the associated RPS sensor channel. The DTM in each instrument channel compares individual monitored variable values with trip setpoint values and for each variable sends a separate, discrete (trip/no trip) output signal to all four divisions of trip logics.

All equipment within an instrument channel is powered from the same division of Class 1E power source. However, different pieces of equipment may be powered from separate DC power supplies. Within an instrument channel, sensors themselves may belong to the RPS or may be components of another system. Signal conditioning and distribution performed by the RMUs is a function of the EMS.

(2) Divisions of Trip Logics

Equipment within a division of trip logic includes primarily manual switches, bypass units (BPUs), trip logic units (TLUs) and output logic units (OLUs), all of which are components of SSLC. The various manual switches provide the operator means to modify the RPS trip logic for special operation, maintenance, testing and reset. The BPUs perform bypass and interlock logic for the channel sensors bypass, main steamline isolation trip special bypass and division trip logic unit bypass. These three

bypasses are all manually initiated through individual keylock switches within each of the four divisions. Each BPU sends a separate bypass signal for all four channels to the TLU in the same division for channel sensors bypass and MSL isolation trip special bypass. Each BPU sends the TLU bypass signal to the OLU in the same division.

The TLUs perform automatic scram initiation logic based on reactor operating mode, channel and division trip conditions and bypass conditions. Each TLU receives bistable input signals from the BPU and various switches in the same division and receives isolated bistable inputs from all four sensor channels and divisions of the NMS.

The OLUs perform division trip, seal-in, reset and trip test function. Each OLU receives bypass inputs from the BPU, trip inputs from the TLU and various manual inputs from switches within the same division and provides discrete trip outputs to the trip actuators in the same division. Each OLU also receives an isolated discrete division trip reset permissive signal from equipment associated with one of the two divisions of scram logic circuitry.

All equipment within a division of trip logic is powered from the same division of Class 1E power source. Both 120 V vital AC (uninterruptible) and 125 VDC Class 1E power are applied simultaneously to the dual low voltage power sources in each SSLC cabinet.

(3) Divisions of Trip Actuators

Equipment within a division of trip actuators include isolated load drivers and relays for automatic scram and air header dump initiation. Each division of trip actuators receives discrete trip inputs from the OLU in the same division.

The isolated load drivers (LDs) are fast response time, bistable, solid state, 120 VAC current interrupting devices that can tolerate the high current levels associated with HCU scram solenoids operation. The operation of the load drivers is such that a trip signal (logic “O” voltage level) on the input side will create a high impedance, current interrupting condition on the output side. The load driver outputs are arranged in the scram logic circuitry between the scram solenoids and scram solenoid 120 VAC power source such that, when in a tripped state, the load drivers will cause de-energization of the scram solenoids (scram initiation). All load drivers within a division interconnect with load drivers in all other divisions to form two separate two-out-of-four scram logic arrangements (Figure 7.2-1).

Isolated load drivers are arranged in the scram logic circuitry between the air header dump valve solenoids and air header dump valve solenoid 125 VDC power source such that, when in a tripped state, the load drivers will cause energization of the air

header dump valve solenoids (backup scram initiation). All load drivers within a division interconnect with load drivers in all other divisions into two separate two-out-of-four air header dump logic arrangements.

(4) Divisions of Manual Scram Controls

Equipment within a division of manual scram controls include manual switches, contacts and relays that provide an alternate, diverse, manual means to initiate a scram and backup scram. Each division of manual scram controls interconnects the actuated load power sources to the same division of scram logic circuitry for scram initiation and to both divisions of scram logic circuitry for backup scram initiation.

(5) Divisions of Scram Logic Circuitry

One of the two divisions of scram logic circuitry distributes Div. II 120 V AC power to the 'A' solenoids of all HCUs, and Div. II 125 VDC power to the solenoid of one of the two air header dump valves. The other division of scram logic circuitry distributes Div. III 120 V AC power to the 'B' solenoids of all HCUs and Div. III 125 VDC power to the solenoid of the other air header dump valve. The HCUs and air header dump valves themselves are not a part of the RPS.

The arrangement of equipment groups within the RPS from sensors to trip actuators is shown in Figure 7.2-1.

7.2.1.1.4.2 Initiating Circuits

The RPS will initiate a reactor scram when any one or more of the following conditions occur or exist within the plant:

- (1) NMS monitored conditions exceed acceptable limits
- (2) High Reactor Pressure
- (3) Low Reactor Water Level (Level 3)
- (4) High Drywell Pressure
- (5) Main Steamline Isolation Valves Closure (Inboard or Outboard)
- (6) Low Control Rod Drive HCU Accumulator Charging Header Pressure
- (7) Turbine Stop Valve Closed
- (8) Turbine Control Valve Fast Closure
- (9) High Suppression Pool Temperature

- (10) High Seismic Acceleration in the Reactor Building
- (11) Operator-initiated Manual Scram

The systems and equipment that provide trip and scram initiating inputs to the RPS for these conditions are discussed in the following subsections. With the exception of the NMS (1), MSIV Closure (5), and the TB-trips (7 and 8) all of the other systems provide sensor outputs through the EMS. Analog-to-digital conversion of these sensor output values is done by EMS equipment. NMS trip signals are provided directly to the RPS by NMS trip logic units. The TB-trips (7 and 8) are provided through hardwired connections.

- (1) Neutron Monitoring System (NMS)

Each of the four divisions of the NMS equipment provides separate, isolated, bistable SRNM and APRM trip signals to all four divisions of RPS trip logics.

- (a) SRNM Trip Signals

The SRNMs of the NMS provide trip signals to the RPS to cover the range of plant operation from source range through startup range to about 15% of reactor rated power. Three conditions monitored as a function of the NMS comprise the SRNM trip logic output to the RPS. These conditions are upscale, short period and SRNM inoperative. The specific condition within the NMS that caused the SRNM trip output is not detectable within the RPS.

- (b) APRM Trip Signals

The APRMs of the NMS provide trip signals to the RPS to cover the range of plant operation from a few percent to greater than reactor rated power. Five conditions monitored as a function of the NMS comprise the APRM trip logic output to the RPS. These conditions are high neutron flux, high simulated thermal power, APRM inoperative, oscillation power range monitor (OPRM) trip, reactor core flow rapid coastdown. The specific condition within the NMS that caused the APRM trip output is not detectable within the RPS.

- (c) OPRM Trip Signals

The OPRM is a functional subsystem of the APRM in each of the four APRM channels. The OPRM trip outputs are combined with other APRM trip signals to produce the final RPS trip signal. The OPRM detects thermal hydraulic instability; its RPS trip function suppresses neutron flux oscillation prior to the violation of safety thermal limits.

- (2) Main Steam System (MS)

- (a) Reactor Pressure

Reactor pressure is measured at four physically separated locations by locally mounted pressure transducers. Each transducer is on a separate instrument line and provides analog equivalent output through the EMS to the SSLC DTM in one of four RPS instrument channels. The pressure transducers and instrument lines are components of MS.

(b) Reactor Water Level

Reactor water level is measured at four physically separated locations by locally mounted level (differential pressure) transducers. Each transducer is on a separate pair of instrument lines and provides analog equivalent output through the EMS to the SSLC DTM in one of the four RPS sensor channels. The level transducers and instrument lines are components of MS.

(c) Drywell Pressure

Drywell pressure is measured at four physically separated locations by locally mounted pressure transducers. Each transducer is on a separate instrument line and provides analog equivalent output through the EMS to the SSLC DTM in one of the four RPS instrument channels of MS.

(d) Main Steamline Isolation

Each of the four main steamlines can be isolated by closing either the inboard or the outboard isolation valve. Separate position switches on both of the isolation valves of one of the main steamlines provide bistable output through the EMS to the SSLC DTM in one of the four RPS instrument channels. Each main steamline is associated with a different RPS sensor channel. The main steamline isolation valves and position switches are components of MS.

(e) High Suppression Pool Temperature

Suppression pool temperature is measured at four physically separated locations by locally mounted sensors. Each sensor provides analog equivalent of suppression pool temperature at various pool levels to the EMS, which, in turn, provides digitized suppression pool temperature data to the suppression pool monitoring (SPTM) module of SSLC. SSLC, after considering pool water level and the operational condition of each sensor, averages the data and provides a trip signal to the corresponding RPS divisional DTM (used for RPS logic) when the calculated average temperature exceeds the setpoint.

(3) Control Rod Drive (CRD) System

(a) CRD Charging Header Pressure

CRD charging header pressure is measured at four physically separated locations by locally mounted pressure transducers. Each transducer is on a separate instrument line and provides analog equivalent output through the EMS to the SSLC DTM in one of the four RPS instrument channels. The pressure transducers and instrument lines are components of the CRD System.

(4) Reactor Protection System

(a) Turbine Stop Valve Closure

Turbine stop valve closure is detected by separate valve stem position switches on each of the four turbine stop valves. Each position switch provides bistable output through hard-wired connections to the SSLC DTM in one of the four RPS instrument channels. The turbine stop valves are components of main turbine; however, the position switches are components of the RPS.

(b) Turbine Control Valve Fast Closure

Low hydraulic trip system oil pressure is detected by separate pressure sensors on each of the four turbine control valve hydraulic mechanisms. Each pressure sensor provides a 4-20 mA signal through hard-wired connections to the SSLC DTM in one of the four RPS instrument channels. The turbine control valve hydraulic mechanisms are components of the main turbine; however, the position and pressure sensors are components of the RPS.

(c) Manual Scram

Two manual scram switches or the reactor mode switch provide the means to manually initiate a reactor scram independent of conditions within the sensor channels, divisions of trip logics and divisions of trip actuators. Each manual scram switch is associated with one of the two divisions of actuated load power.

In addition to the scram initiating variables monitored by the RPS, one bypass initiating variable is also monitored.

(d) Turbine Bypass Valve Position

The Turbine Bypass Valves provide limit (position) switch inputs to RPS as a permissive signal to inhibit reactor trip on Turbine Stop Valve closure or Turbine Control Valve fast closure if the bypass valves open to their 10% position within a defined period of time. One switch with four sets of contacts are mounted on each valve. Each contact closure is sent to a different division (each valve sends their contact closures in the same manner) to permit a single-failure proof 2-out-of-4 coincidence vote. These Class 1E switches are part of RPS.

(e) Seismic Activity Acceleration Switches

Seismic activity is detected by three sets of four separate acceleration switches. One set of four acceleration switches monitors reactor building bottom horizontal acceleration, the second set of four acceleration switches monitors reactor building bottom vertical acceleration and the third set of four acceleration switches monitors reactor building top horizontal acceleration. These seismic activity monitoring acceleration switches are locally mounted and are components of the RPS. Each of the four switches associated with each of the three sets are each assigned to separate RPS electrical divisions. Each switch shall provide bistable output by hardwired connection to one of the four SSLC DTMs associated with the RPS divisional instrument channels.

7.2.1.1.4.3 RPS Logic

The combination of division trip, scram, reset and bypass logic that make up the overall RPS logic is shown in Figure 7.2-1. Each division trip logic receives trip inputs from all four sensor channels and NMS divisions and provides a sealed-in trip output to the scram logic when the same trip condition exists in any two or more sensor channels or NMS divisions. At the division trip logic level, various trips and trip initiating conditions can be bypassed as described in the following subsections. The scram logic will initiate a reactor scram when a trip condition exists in any two or more division trip logics. At the scram logic level, no bypasses are possible.

(1) Channel of Sensors Bypass

A separate manual keylock switch in each of the four divisions of SSLC provides means to bypass the collective trip outputs of the associated instrument channel. The effect of the channel of sensors bypass is to reduce all four division trips to a coincidence of two out of three tripped instrument channels. Interlocks between the four divisions of trip logic prevent bypass of any two or more sensor channels at the same time. Once a bypass of one instrument channel has been established, bypasses of any of the remaining three sensor channels are inhibited.

A channel of sensors bypass in any channel will bypass all trip initiating input signals except those trip signals received from the NMS.

(2) Division Trip Logic Unit Bypass

A separate manual keylock switch in each of the four divisions of SSLC provides means to bypass that division's trip unit output to the scram logic. The effect of the division trip logic bypass is to reduce the scram logic to a coincidence of two out of three tripped divisions. Interlocks between the four division trip logic bypasses prevent bypass of any two or more division trip logics at the same time. Once a bypass of one division of trip logic has been established, bypasses of any of the remaining three division trip logics are inhibited.

(3) MSL Isolation Special Bypass

A separate manual keylock switch associated with each of the four instrument channels provides means to bypass the MSL isolation trip output signal from the instrument channel to all four divisions of trip logic. This bypass permits continued plant operation while any one MSL is isolated without causing a half scram condition. The effect of the MSL isolation special bypass is to reduce the MSL isolation trip function in all four divisions of trip logic to a coincidence of two out of three instrument channel MSL isolation trips. Interlocks between the four divisions of trip logic prevent MSL isolation special bypass in any instrument channel when either a channel of sensors bypass or a MSL isolation special bypass is present in any other instrument channel. Once a MSL isolation special bypass has been established in one instrument channel, the same bypass is inhibited in the other three channels. This bypass is inhibited in all three remaining channels when any channel of sensor bypass exists.

(4) Bypass of Scram Trip due to Mode Switch in Shutdown Position

The RPS trip caused by the reactor mode switch being placed in the shutdown position is automatically bypassed after a period lasting approximately 10 seconds. This bypass permits resetting of the trip actuators and re-energization of the scram pilot valve solenoids. This trip can be permanently bypassed for the duration of a maintenance outage using two keylocked switches under administrative control so that the scram valves do not experience unnecessary wear during repeated surveillance activities.

(5) Trip Logic and Operating Bypasses

Neutron Monitoring System (NMS) Trips

A coincident NMS trip will occur in each division of trip logic when any two or more out of four divisions of APRM, OPRM or SRNM trip signals are received from the NMS. The coincident SRNM trip is automatically bypassed when the reactor is in the run mode. The coincident APRM or OPRM trip cannot be bypassed within SSLC. APRM, OPRM and SRNM trips have manual bypass capabilities within NMS.

A non-coincident NMS trip will occur in each division of trip logic when any single APRM or SRNM trip signal is received from the NMS if the coincident/non-coincident manual switch in each division of RPS is in the non-coincident position. The non-coincident NMS trip is automatically bypassed when the reactor is in the Run mode. When the reactor is in the shutdown, refuel or startup mode, the non-coincident NMS trip can be manually bypassed in each division by a separate, manual, keylock non-coincident NMS trip disable switch.

Main Steamline Isolation Trip

A MSL isolation trip will occur in each division of trip logic when either the inboard or outboard MSL isolation valve is closed in any two or more unbypassed sensor channels. When the reactor is in the shutdown, refuel or startup mode, the MSL isolation trip function is automatically bypassed in each division of trip logic when reactor pressure in the associated sensor channel is below the bypass setpoint. This bypass permits plant operation when the MSIVs are closed during low power operation.

Control Rod Drive (CRD) HCU Accumulator Charging Header Low Pressure Trip

A low CRD HCU accumulator charging header pressure trip will occur in each division of trip logic when CRD charging header pressure is low in any two or more unbypassed instrument channels. This bypass is allowed only whenever the reactor mode switch is either in “Shutdown” or “Refuel” mode position. When the reactor is in the shutdown or refuel mode, the low CRD HCU accumulator charging header pressure trip can be manually bypassed in each division of trip logic by separate, manual, keylock CRD HCU accumulator charging header pressure trip bypass switches. This bypass allows RPS reset after a scram while CRD charging header pressure is below the trip setpoint. Each division of trip logic sends a separate rod withdraw block signal to the RCIS when this bypass exists in the division.

Turbine Stop Valve Closed and Turbine Control Valve Fast Closure Trips

A turbine stop valve closed trip will occur in each division of trip logic when the turbine stop valve is closed in any two or more unbypassed sensor channels. A turbine control valve fast closure trip will occur in each division of trip logic when either the fast acting solenoid valve is closed or the hydraulic trip system (HTS) oil pressure is below the trip setpoint in any two or more unbypassed instrument channels. Both of these trips are automatically bypassed in each division of trip logic when the reactor power level is below the bypass setpoint. Each division of trip logic sends a separate recirculation pump trip initiating signal to the recirculation system when these trips occur in the division.

High Reactor Pressure Trip

A high reactor pressure trip will occur in each division of trip logic when reactor pressure is above the trip setpoint in any two or more unbypassed sensor channels. There are no operating bypasses associated with this trip function.

Low Reactor Water Level Trip

A low reactor water level trip will occur in each division of trip logic when reactor water level is below the trip setpoint in any two or more unbypassed sensor channels. There are no operating bypasses associated with this trip function.

High Drywell Pressure Trip

A high drywell pressure trip will occur in each division of trip logic when drywell pressure is above the trip setpoint in any two or more unbypassed sensor channels. There are no operating bypasses associated with this trip function.

High Seismic Activity Trip

A high seismic activity trip occurs in each division of trip logic when seismic activity trip condition exists in any two or more unbypassed instrument channels. There are no operating bypasses associated with this trip function.

High Suppression Pool Temperature

A high suppression pool temperature trip will occur in each division of the trip logic when suppression pool temperature is above the trip setpoint in any two or more unbypassed sensor channels. There are no operating bypasses associated with this trip function.

Full Load Rejection without Scram Capability

Full load rejection and turbine trip without reactor scram is provided by the Steam Bypass and Pressure Control (SBPC) system in conjunction with the Recirculation Flow Control (RFC) System, RCIS, and SSLC. Upon full load rejection signal, the turbine control valves are fast closed by the turbine control system and the turbine bypass valves are fast opened. Upon a full load rejection, recirculation flow is automatically reduced and the selected control rods run-in (SCRRI) function (electric run-in of selected FMCRDs) is initiated to reduce turbine bypass steam flow to the main condenser. When the turbine control valves have fast closed, reactor trip signals are generated by the hydraulic pressure sensors located at the turbine control valves and transmitted to RPS. A time delay is applied to these signals. During this time delay, if the required number of bypass valves are opening as indicated by their 10% position sensors, reactor scram and recirculation pump trip (RPS) are inhibited. The time delay is chosen such that if the bypass valves fail to open, acceptable thermal limits are maintained.

Turbine Trip without Scram Capability

For turbine trip, the control actions are similar to that above for full load rejection. Turbine stop valve position signals are sent to the RPS. If the bypass valves are opening as indicated by the 10% position sensors, reactor scram and RPT are

inhibited. Recirculation flow reduction and SCRRRI are initiated. If the main turbine is tripped because of high condenser pressure, as indicated by condenser pressure sensor signals sent to the SSLC, reactor scram and RPT will initiate to shut off steam flow to the main condenser to protect the main turbine and to avoid the potential for rupturing the low pressure turbine casing.

(6) Manual Scram

A sealed-in manual scram of all HCUs and associated control rods will occur when both manual scram pushbuttons are armed and depressed or when the reactor mode switch is placed in the shutdown position. Depressing only one armed scram pushbutton will result in a sealed-in half scram (current interruption for one of the two divisions of scram circuitry). The scram initiating input received from the mode switch shutdown contacts is automatically bypassed after a sufficient time delay (10 s) to allow for scram seal-in and full insertion of all control rods.

A separate manual pushbutton switch in each of the four divisions provides means to manually trip all trip actuators in that division. This sealed-in division manual trip is equivalent to a sealed-in automatic trip from the same division of trip logic. An alternative manual scram can be accomplished by depressing any two or more of the four division manual trip pushbuttons.

(7) Reset Logic

A single manual three-position toggle switch provides means to reset the manual scram seal-in circuitry in both divisions of manual scram controls. If either of the manual scram pushbuttons is still depressed when a reset is attempted, the reset will not have any effect.

A separate manual pushbutton associated with each division of trip actuators provides means to reset the seal-in at the input of all trip actuators in the same division. If the conditions that caused the division trip have not cleared when a reset is attempted, the reset will not have any effect. After a single division trip, reset is possible immediately; however, if a full scram has occurred, reset is inhibited for 10 seconds to allow sufficient time for scram completion.

As a consequence of a full scram, the CRD charging header pressure will drop below the trip setpoint, resulting in a trip initiating input to all four divisions of trip logic. While this condition exists, reset of the manual scram circuitry is possible; however, the four divisions of trip logic cannot be reset until the CRD charging pressure trip is manually bypassed in all four divisions and all other trip initiating conditions have cleared.

7.2.1.1.4.4 Redundancy and Diversity

Instrument sensing lines from the reactor vessel are routed through the drywell and terminate outside the primary containment. Instruments mounted on instrument racks in the four quadrants of the reactor building sense reactor vessel pressure and water level from this piping. Valve position switches are mounted on valves from which position information is required. The sensors for RPS signals from equipment in the Turbine Building are mounted locally. The four battery-powered inverters, which serve as the divisional 120 VAC power supplies for the SSLC and RPS are located in an area where they can be serviced during reactor operation. Sensor signals (via the EMS) and power cables are routed to four SSLC divisional cabinets in the divisional electrical compartments. One logic panel is used for each division.

The redundant portions of the RPS have physically separated sensor taps, sensing lines, sensors, sensor rack locations, cable routing, and termination in four separate SSLC panels in the MCR. By the use of four or more separate redundant sensors for each RPS variable with separate redundant logic and wiring, the RPS has been protected from a credible single failure. For additional information on redundancy of RPS subsystems, refer to Subsection 7.2.1.1.4.2. For information on the protection provided within SSLC and RPS against common-mode failure of the redundant channels, refer to Section 7.8.

Redundancy of the RPS logic power supply is provided. There are four Class 1E uninterruptible power sources and four Class 1E DC power sources which supply electrical power, one set to each division of the RPS. A loss of one power supply will neither inhibit protective action nor cause a scram.

7.2.1.1.4.5 Actuated Devices

The devices actuated by the RPS trip and scram logic include the 120 VAC-powered 'A' and 'B' scram solenoids of the HCU of each control rod drive pair and the 125 VDC-powered air header dump valves. The 'A' solenoids of the HCUs are energized by division II power and the 'B' solenoids by division III power. When any single RPS division is in a tripped state or when only one of the manual scram pushbuttons is depressed, all of either the 'A' or the 'B' solenoids will be de-energized, resulting in a half-scram condition. A full scram of a control rod drive pair will occur when both the 'A' and 'B' solenoid of the HCU are de-energized. The HCUs and associated control rod pairs are divided into four groups. The RPS supplies power to each group from separate RPS power distribution circuits. The combination of control rods within each group is such that hot shutdown can be achieved even in the event of failure to scram of an entire rod group.

The solenoid of one of the air header dump valves is energized by one division of DC power and the solenoid of the other air header dump valve is energized by another division of DC power. When the solenoid of either of the air header dump valves is energized, the air header will be released, resulting in insertion of all control rods. The arrangement of RPS equipment is shown on Figure 7.2-1.

7.2.1.1.4.6 Separation

Four independent sensor channels monitor the various process variables listed in Subsection 7.2.1.1.4.2. The redundant sensor devices are separated so that no single failure can prevent a scram. Locations for local RPS racks and panels are shown on the instrument location drawings provided in Section 1.7. Divisional separation is also applied to the Essential Multiplexing System (EMS), as discussed in Section 7.9, which provides data highways for the sensor input to the logic units. The four divisions of RPS scram logic reside in four physically separated SSLC cabinets. Fiber-optic cable routing from remote multiplexing units (RMUs) of EMS to control room equipment is shown in raceway plans provided by reference in Section 1.7. The criteria for separation of sensing lines and sensors are discussed in Section 7.1.

The mode switch, low CRD accumulator charging pressure trip and other selected bypass switches, scram reset switches and manual scram switches are all mounted on the principal control console. Each device is mounted in a metal enclosure and has a sufficient number of barrier devices to maintain adequate separation between redundant portions of the RPS.

The outputs from the SSLC logic cabinets to the scram pilot valve solenoids are run in separate rigid conduits with no other wiring. The four wireways match the four scram groups. The groups are selected so that the failure of one group to scram will not prevent a reactor shutdown. The scram group conduits have unique identification and are separately routed as Division II and III conduits for the A and B solenoids of the scram pilot valves, respectively. This corresponds to the divisional assignment of their power sources.

Signals which must run between redundant RPS divisions are electrically/physically isolated by isolators to provide separation.

RPS inputs to annunciators, recorders, and the computer are arranged so that no malfunction of the annunciating, recording, or computing equipment can functionally disable the RPS. Direct signals from RPS sensors are not used as inputs to annunciating or data-logging equipment. Electrical isolation is provided by the SSLC controllers between the primary signal and the information output by fiber-optic cable interfaces.

7.2.1.1.5 Environmental Considerations

Electrical equipment for the RPS is located in the Control Building, Reactor Building, and in the Turbine Building. The environmental conditions for these areas are shown in Section 3.11.

7.2.1.1.6 Operational Considerations

7.2.1.1.6.1 Reactor Operator Information

- (1) Indicators

Scram group indicators extinguish when actuator logic prevents output current from the 120 VAC power source from reaching the scram pilot valve solenoid associated with the actuator logic.

Information regarding trip parameters such as reactor vessel water level and reactor power level is displayed in the MCR.

(2) Annunciators

Each RPS trip channel input is provided to annunciators of the plant computer system through isolation devices. Trip logic trips, manual trips, and certain bypasses also signal the annunciators. Safety-related annunciation is provided by dedicated displays in each division on the main control console that are connected directly to SSLC by fiber optic data links.

All RPS instrument channel trips shall initiate an annunciation of the variable, causing the trip in the MCR to alert the plant operator of a trip condition. The final output trips for each RPS division shall have separate single annunciation of the tripped condition of each RPS division. All bypassed RPS instrument channels or division logics whose bypassed condition is not a normal condition of operation shall also be annunciated. As an annunciator input, a channel trip also sounds an audible alarm which can be silenced by the operator. The annunciator displays latch in until reset manually. Reset is not possible until the condition causing the trip has been cleared.

(3) Computer Alarms

A computer printout identifies each tripped channel; however, status indication at the RPS trip channel device may also be used to identify the individual sensor that tripped in a group of sensors monitoring the same variable.

Upon detection of a status change of any of the preselected sequential events contacts, the sequence-of-events log shall be initiated and shall signal the beginning of an event. This log will include both nuclear island (NI) and balance of plant (BOP) inputs. Changes of state received 5 milliseconds or more apart are sequentially differentiated on the printed log, together with time of occurrence, which shall be printed in hours, minutes, seconds, and milliseconds. Use of the alarm printer and computer is not required for plant safety. The printout of trips is particularly useful in routinely verifying the correct operation of pressure, level, and valve position switches as trip points are passed during startup, shutdown, and maintenance operations.

7.2.1.1.6.2 Reactor Operator Controls—Mode Switch

A conveniently-located, multiposition, keylock mode switch is provided to select the necessary scram functions for various plant conditions. The mode switch selects the appropriate sensors for scram functions and provides appropriate bypasses. The switch also interlocks such functions as control rod blocks and refueling equipment permissives which are not considered as part of the RPS. The switch is designed to provide separation between signals to the four trip logic divisions. The mode switch positions and their related functions are as follows:

- (1) SHUTDOWN
 - Initiates a reactor scram
 - Selects lower NMS neutron flux trip setpoint
 - Enables NMS SRNM trips
 - Enables manual selection of non-coincident NMS trip function
 - Enables manual CRD charging pressure trip bypass and automatically bypasses the following trip functions:
 - (a) Turbine control valve fast closure trip
 - (b) Turbine stop valve closure trip
 - (c) MSIV closure trip if reactor pressure is below bypass setpoint
- (2) REFUEL
 - Enables same trip bypasses and NMS trip functions as SHUTDOWN mode.
- (3) STARTUP
 - Enables same trip and bypass functions as REFUEL mode except when CRD charging pressure trip bypass is disabled.
- (4) RUN
 - Disables all trip bypasses enabled by any of the other three modes.
 - Disables SRNM trip and non-coincident NMS trip and deselects lower NMS neutron flux trip setpoint.

Mode switch position is also provided for use by other systems, including NMS, RCIS and LDI.

7.2.1.1.7 Setpoints

Instrument ranges are chosen to cover the range of expected conditions for the variable being monitored. Additionally, the range is chosen to provide the necessary accuracy for any required setpoints and to meet the overall accuracy requirements of the channel.

(1) Neutron Monitoring System Trip

To protect the fuel against high heat generation rates, neutron flux is monitored and used to initiate a reactor scram. The NMS is discussed in Section 7.6.

(2) Reactor Vessel System High Pressure

Excessively high pressure within the reactor vessel threatens to rupture the reactor coolant pressure boundary. A reactor vessel pressure increase during reactor operation compresses the steam voids and results in a positive reactivity insertion. This causes increased core heat generation that could lead to fuel failure and system overpressurization. A scram counteracts a pressure increase by quickly reducing core fission-heat generation. The reactor vessel high-pressure scram setting is chosen slightly above the reactor vessel maximum normal operation pressure to permit normal operation without spurious scram yet provide a wide margin to the maximum allowable reactor vessel pressure. The location of the pressure measurement, as compared to the location of highest nuclear system pressure during transients, was also considered in the selection of the high-pressure scram setting. The reactor vessel high-pressure scram works in conjunction with the pressure-relief system to prevent reactor vessel pressure from exceeding the maximum allowable pressure. The reactor vessel high-pressure scram setting also protects the core from exceeding thermal hydraulic limits that result from pressure increases during events that occur when the reactor is operating below rated power and flow.

(3) Reactor Vessel Low Water Level

Low water level in the reactor vessel indicates that the reactor is in danger of being inadequately cooled. Should water level decrease too far, fuel damage could result as steam forms around fuel rods. A reactor scram protects the fuel by reducing the fission-heat generation within the core. The reactor vessel low water level scram setting was selected to prevent fuel damage following abnormal operational transients caused by single equipment malfunctions or single operator errors that result in a decreasing reactor vessel water level. The scram setting is far enough below normal operational levels to avoid spurious scrams. The setting is high enough above the top of the active fuel to assure that enough water is available to account for evaporation loss and displacement of coolant following the most severe abnormal operation transient involving a level decrease.

(4) Turbine Stop Valve Closure

Closure of the turbine stop valve with the reactor at power can result in a significant addition of positive reactivity to the core as the reactor vessel pressure rise causes steam voids to collapse. The turbine stop valve closure scram initiates a scram earlier than either the Neutron Monitoring System or reactor vessel high pressure. The scram counteracts the addition of positive reactivity caused by increasing pressure by inserting negative reactivity with control rods. Although the reactor vessel high-pressure scram, in conjunction with the pressure relief system, is adequate to preclude over-pressurizing the nuclear system, the turbine stop valve closure scram provides additional margin to the reactor vessel pressure limit. The turbine stop valve closure scram setting provides the earliest positive indication of valve closure.

(5) Turbine Control Valve Fast-Closure

With the reactor and turbine generator at power, fast closure of the turbine control valves can result in a significant addition of positive reactivity to the core as nuclear system pressure rises. The turbine control valve fast-closure scram initiates a scram earlier than either the neutron monitoring system or nuclear system high pressure. The scram counteracts the addition of positive reactivity resulting from increasing pressure by inserting negative reactivity with control rods. Although the nuclear system high-pressure scram, in conjunction with the pressure relief system, is adequate to preclude over-pressurizing the nuclear system, the turbine control valve fast-closure scram provides additional margin to the nuclear system pressure limit. The turbine control valve fast-closure scram setting is selected to provide timely indication of control valve fast closure.

(6) Main Steamline Isolation

The main steamline isolation valve closure can result in a significant addition of positive reactivity to the core as nuclear system pressure rises. The main steamline isolation scram setting is selected to give the earliest positive indication of main steamline isolation without inducing spurious scrams.

(7) Low Charging Pressure to Control Rod Drive Hydraulic Control Unit Accumulators

The CRD Hydraulic System normally supplies charging water at sufficient pressure to charge all scram accumulators of the individual control rod HCUs to pressure values that will assure adequate control rod scram insertion rates during a full reactor trip or scram. A low charging water pressure is indicative of the potential inability to maintain the scram accumulators pressurized. A reactor trip is initiated after a specified time delay, before the charging water pressure drops to a value that could eventually result in slower than normal scram speed control rod insertion.

(8) Drywell High Pressure

High pressure inside the drywell may indicate a break in the reactor coolant pressure boundary. It is prudent to scram the reactor in such a situation to minimize the possibility of fuel damage and to reduce energy transfer from the core to the coolant. The drywell high-pressure scram setting is selected to be as low as possible without inducing spurious scrams.

(9) High Seismic Activity

Automatic reactor scram shall be initiated when the condition of high seismic acceleration is detected by the accelerometers located in the reactor building.

(10) High Suppression Pool Temperature

Automatic reactor scram shall be initiated when the condition of high suppression pool temperature is sensed. This is discussed in the high suppression pool temperature monitoring system in Subsection 7.2.1.1.4.2(2)(e).

7.2.1.1.8 Containment Electrical Penetration Assignment

Electrical containment penetrations are assigned to the protection systems on a four-division basis (Subsections 7.2.1.1.4.1 and 4.6).

Each penetration is provided with a NEMA-4 enclosure box on each end, providing continuation of the metal wire ways (Subsection 7.2.1.1.5.6).

7.2.1.1.9 Main Control Room (MCR) Area

Virtually all hardware within the RPS design scope is located within the four separate and redundant safety system logic and control (SSLC) cabinets in the MCR area, except for the instrumentation monitoring turbine stop valve closure, turbine control valve fast closure, and turbine bypass valve position. The equipment for initiating RPS scram time testing is also located outside the MCR area. The SSLC panels are mounted in the divisional back panel areas of the MCR. The major control switches are located on the main control console.

7.2.1.1.10 Control Room Cabinets and Their Contents

The SSLC logic cabinets, which contain the RPS functions for Divisions I, II, III, and IV, include a separate cabinet for each division. The cabinets contain digital and solid-state discrete and integrated circuits used to condition signals transferred to the SSLC from EMS. They also contain combinational and sequential logic circuits for the initiation of safety actions and/or alarm annunciation, isolators for electrical and physical separation of circuits used to transmit signals between redundant safety systems or between safety and non-safety systems, and system support circuits such as power supplies, automatic testing circuits, etc. Load drivers with solid-state switching outputs for actuation of solenoids are located in the MCR.

The main control console contains the reactor mode switch, the RPS manual scram pushbutton switches, the CRD scram reset switches and the bypass switches for the low CRD accumulator charging pressure.

Load Drivers

Load drivers are trip actuators that implement RPS output coincidence logic by means of their arrangement and interconnections. The load drivers (LDs) are bistable, solid-state, 120 VAC current-interrupting devices that are normally kept energized to maintain the fail-safe structure of the trip systems. A trip signal on the input side of the LDs (which is sent from the OLU) creates a high impedance, current-interrupting condition on the output side. The LDs are inserted in the power circuit path between the scram pilot valve solenoids and their power source such that when in the tripped state, they cause de-energization of the scram pilot valve solenoids. The LDs are components of SSLC and are located in the SSLC divisional cabinets in the MCR back panel area. The main control console contains the reactor mode switch, the RPS manual scram pushbutton switches, the CRD scram reset switches and the bypass switches for the low CRD HCU accumulator charging pressure. The wide display behind the main control console contains SSLC bypass switches that can bypass process sensor inputs to each RPS channel's trip logic and can also bypass divisional trip logic outputs to the actuating devices for the scram pilot valve solenoids.

7.2.1.1.11 Test Methods That Enhance RPS Reliability

Surveillance Testing

Surveillance testing is performed periodically on the RPS during operation. This testing includes sensor calibration, response-time testing, trip channel actuation, and trip time measurement with simulated inputs to individual trip modules and sensors. The sensor channels can be checked during operation by comparison of the associated MCR displays on other channels of the same variable.

7.2.1.1.12 Interlock Circuits to Inhibit Rod Motion

Interlocks between the RPS and RCIS inhibit rod withdrawal when the CRD accumulator charging pressure trip bypass switch is in the BYPASS position. These interlocks assure that no rods can be withdrawn when conditions are such that the RPS cannot reinsert rods if necessary.

7.2.1.1.13 Support Cooling System and HVAC Systems Descriptions

The cooling (ventilating) systems important for proper operation of RPS and SSLC equipment are described in Section 9.4.

7.2.1.2 Design Bases

Design basis information requested by IEEE-279 is discussed in the following paragraphs. These IEEE-279 design basis aspects are considered separately from those more broad and detailed design bases for this system cited in Subsection 7.1.2.2.

(1) Conditions

Generating station conditions requiring RPS protective actions are defined in Chapter 16 (Technical Specifications).

(2) Variables

The generating station variables which are monitored cover the protective action conditions that are identified in Subsection 7.2.1.1.4.2.

(3) Sensors

A minimum number of LPRMs per APRM are required to provide adequate protective action. This is the only variable that has spatial dependence (IEEE-279, Paragraph 3.3).

(4) Operational Limits

Operational limits for each safety-related variable trip setting are selected with sufficient margin to avoid a spurious scram. It is then verified by analysis that the release of radioactive material following postulated gross failure of the fuel or the reactor coolant pressure boundary is kept within acceptable bounds. Design basis operational limits in Chapter 16 are based on operating experience and constrained by the safety design basis and the safety analyses.

(5) Margin Between Operational Limits

The margin between operational limits and the limiting conditions of operation (scram) for the RPS are described in Chapter 16 of the FSAR. The margin includes the maximum allowable accuracy error, sensor response times, and sensor setpoint drift.

(6) Levels Requiring Protective Action

Levels requiring protective action are provided in Chapter 16 of the FSAR. These levels are design basis setpoints and are at least as limiting as the limiting safety system settings provided in Chapter 16 of the FSAR.

(7) Ranges of Energy Supply and Environmental Conditions

The RPS 120 VAC power is provided by the four battery-powered inverters, for the SSLC, each with an alternate Class 1E 120 VAC supply. The batteries, which are designed for a two-hour minimum capacity, have sufficient stored energy to ride through switching transients in the switch yards in order to prevent switching transients from causing a scram. The alternate sources of 120V power are provided to each SSLC bus from transformers powered from the 4.16 kV emergency diesel generators. Since there are three diesel generators, the fourth division alternate power originates from the first division diesel.

Environmental conditions for proper operation of the RPS components are covered in Section 3.11.

(8) Unusual Events

Unusual events are defined as malfunctions or accidents and other events which could cause damage to safety systems. Chapter 15 (Accident Analyses) describes the following credible accidents and events: floods, storms, tornados, earthquakes, fires, LOCA, pipe break outside the containment, and feedwater line break. A discussion of each of these events, as applicable to the subsystems of the RPS, follows:

(a) Floods

The buildings containing RPS and SSLC components have been designed to meet the probable maximum flood (PMF) at the site location. This ensures that the buildings will remain watertight under PMF; therefore, none of the RPS functions are affected by flooding. Internal flooding sources are covered in Section 3.4.

(b) Storms and Tornados

The buildings containing RPS and SSLC components have been designed to withstand all credible meteorological events and tornados as described in Section 3.3. Superficial damage may occur to miscellaneous station property during a postulated tornado but this will not impair the RPS capabilities.

(c) Earthquakes

The structures containing RPS and SSLC components, except the turbine building, have been seismically qualified (Sections 3.7 and 3.8) and will remain functional during and following a safe shutdown earthquake (SSE). Since reactor high pressure and power trips are diverse to the turbine scram variables, locating these sensors in the turbine enclosure does not compromise the ability of the RPS to provide protective action when required.

(d) Fires

To protect the RPS in the event of a postulated fire, the RPS trip logics are contained within the four separate independent SSLC cabinets. The separation of the cabinets and their individual steel construction assures that the RPS functions will not be prevented by a postulated fire within any of the divisional panels. Incombustible or fire retardant materials are used as much as possible. The use of separation and fire barriers ensures that even though some portion of the system may be affected, the RPS will continue to provide the required protective action (Section 9.5).

(e) LOCA

The following subsystem components are located inside the drywell and would be subjected to the effects of a design basis LOCA:

- (i) Neutron Monitoring System (NMS) cabling from the detectors to the MCR
- (ii) MSIV Inboard Position Sensors
- (iii) Reactor vessel pressure and reactor vessel water level instrument taps and sensing lines which terminate outside the drywell; and drywell pressure taps

These items have been environmentally qualified to remain functional during and following a LOCA as discussed in Section 3.11.

(f) Pipe Break Outside Containment

This condition will not affect the reliability of the RPS.

(g) Feedwater Break

This condition will not affect the RPS.

(h) Missiles

Missile protection is described in Section 3.5.

(9) Performance Requirements

The minimum performance requirements are provided in Chapter 16 of the FSAR.

A logic combination (two out of four) of instrument channel trips actuated by abnormal or accident conditions will initiate a scram and produce independent logic seal-ins within each of the four logic divisions. The trip conditions will be annunciated and recorded via the plant computer system. The trip seal-in will maintain a scram signal condition at the CRD System terminals until the trip channels

have returned to their normal operating range and the seal-in is manually reset by operator action. Thus, once a trip signal is present long enough to initiate a scram and the seal-ins, the protective action will go to completion.

7.2.2 Conformance Analysis

This subsection presents an analysis of how the various functional requirements and the specific regulatory requirements of the RPS design bases are satisfied.

7.2.2.1 Conformance to Design Bases Requirements

(Statements of the Design Bases Are Given in Section 7.1.2.2.)

(1) Design Bases 7.1.2.2(1)(a)

The RPS is designed to provide timely protection against the onset and consequences of conditions that threaten the integrity of the fuel barrier. Chapter 15 identifies and evaluates events that jeopardize the fuel barrier. The methods of assessing barrier damage and radioactive material releases, along with the methods by which abnormal events are sought and identified, are presented in that chapter.

Design bases require that the precision and reliability of the initiation of reactor scrams be sufficient to prevent or limit fuel damage.

Table 7.2-1 provides a listing of the sensors selected to initiate reactor scrams and delineates the range for each sensor. Setpoints, accuracy and response time can be found in Chapter 16 of the FSAR. This information establishes the precision of the RPS variable sensors.

The selection of scram trip settings has been developed through analytical modeling, historical use of initial setpoints and adoption of new variables and setpoints as experience was gained. The initial setpoint selection method provided for settings which were sufficiently above the normal operating levels (to preclude the possibilities of spurious scrams or difficulties in operation) but low enough to protect the fuel. As additional information became available or systems were changed, additional scram variables were provided using the above method for initial setpoint selection. The selected scram settings are analyzed to verify that they are conservative and that the fuel and fuel barriers are adequately protected. In all cases, the specific scram trip point selected is a conservative value that prevents damage to the fuel taking into consideration previous operating experience and the analytical models.

(2) Design Basis 7.1.2.2.(1)(b)

The scram initiated by reactor high pressure, in conjunction with the pressure relief system, is sufficient to prevent damage to the reactor coolant pressure boundary as a result of internal pressure. The MSIV closure scram provides a greater margin to the RCPB pressure safety limit than does the high pressure scram. For turbine generator trips, the stop valve closure scram and turbine control valve fast closure scram provide a greater margin to the nuclear system pressure safety limit than does the high pressure scram. Chapter 15 identifies and evaluates accidents and abnormal operational events that result in nuclear system pressure increases. In no case does pressure exceed the RCPB safety limit.

- (3) The scram initiated by the reactor vessel low-water level satisfactorily limits the radiological consequences of gross failure of the fuel or RCPB. Chapter 15 evaluates gross failure of the fuel and the RCPB. In no case does the release of the radioactive material to the environs result in exposure which exceeds the guidelines of applicable published regulations.
- (4) Design Basis 7.1.2.2(1)(d)

Scrams are initiated by variables which are designed to indirectly monitor fuel temperature and protect the reactor coolant pressure boundary. The NMS monitors fuel temperature indirectly using incore detectors. The incore detectors monitor the reactor power level by detecting the neutron level in the core. Reactor power level is directly proportional to neutron level and the heat generated in the fuel. Although the NMS does not monitor fuel temperature directly by establishing a correlation between fuel temperature and reactor power level, scram setpoints can be determined for protective action which will prevent fuel damage.

The RCPB is protected by monitoring parameters which indicate reactor pressure directly or anticipate reactor pressure increases. Reactor pressure is monitored directly by pressure sensors which are connected directly to the reactor pressure vessel through sensing lines and pressure taps. In addition, reactor pressure transients are anticipated by monitoring the closure of valves which shut off the flow of steam from the reactor pressure vessel and cause rapid pressure increases. The variables monitored to anticipate pressure transients are MSIV position, turbine stop valve closure, and turbine control valve fast closure. If any of these valves were to close, pressure would rise very rapidly; therefore, this condition is anticipated and a trip is initiated to minimize the pressure transient occurring.

Chapter 15 identifies and evaluates those conditions which threaten fuel and RCPB integrity. In no case does the core exceed a safety limit.

- (5) Design Basis 7.1.2.2(1)(e)

The scrams initiated by the NMS, drywell pressure, reactor vessel pressure, high suppression pool temperature, reactor vessel water level, turbine stop valve closure, MSIV bypass, and turbine control valve fast closure will prevent fuel damage. The scram setpoints and response time requirements for these variables are identified in Chapter 16 of the FSAR and have been designed to cover the expected range of magnitude and rates of change during abnormal operational transients without fuel damage. Chapter 15 identifies and evaluates those conditions which threaten fuel integrity. With the selected variables and scram setpoints, adequate core margins are maintained relative to thermal/hydraulic safety limits.

(6) Design Basis 7.1.2.2(1)(f)

Neutron flux is the only essential variable of significant spatial dependence that provides inputs to the RPS. The basis for the number and locations follows. The other requirements are fulfilled through the combination of logic arrangement, channel redundancy, wiring scheme, physical isolation, power supply redundancy, and component environmental capabilities.

Two transient analyses are used to determine the minimum number and physical location of required LPRMs for each APRM.

- (a) The first analysis is performed with operating conditions of 100% reactor power and 100% recirculation flow using a continuous rod withdrawal of the maximum worth control rod. In analysis, LPRM detectors are mathematically removed from the APRM channels. This process is continued until the minimum numbers and locations of detectors needed to provide protective action are determined for this condition.
- (b) The second analysis is performed with operating conditions of 100% reactor power and 100% recirculation flow using a reduction of recirculation flow at a fixed design rate. LPRM detectors are mathematically removed from the APRM channels. This process is continued until the minimum numbers and locations of detectors needed to provide protective action are determined for this condition.

The results of the two analyses are analyzed and compared to establish the actual minimum number and location of LPRMs needed for each APRM channel.

(7) RPS Design Basis 7.1.2.2.1(1)(g) through (n)

Sensors, channels, and logics of the RPS are not used directly for automatic control of process systems except for an isolated end-of-cycle recirculation pump trip signal to the recirculation flow control system resulting from turbine stop valve closure or turbine control valve fast closure. An isolated NMS signal is also used with the

recirculation flow control system (Section 7.7); therefore, failure in the controls and instrumentation of process systems cannot induce failure of any portion of the protection system.

Failure of any RPS power supply would result in de-energizing one of the two scram valve pilot solenoids on each scram valve. Alternate power is available to the RPS buses. A complete sustained loss of electrical power to two or more power supplies would result in a scram.

The RPS is designed so that it is only necessary for trip variables to exceed their trip setpoints for sufficient length of time to trip the digital trip modules and seal-in the associated trip logic. Once this is accomplished, the scram will go to completion regardless of the state of the variable which initiated the protective action.

When the initiating condition has cleared and a sufficient (10 seconds) time delay has occurred, the scram may be reset only by operator actuation of the scram reset switches in the MCR.

RPS cabling is routed in separate raceways or conduits for each division for all wiring for sensors, racks, panels, and scram solenoids.

Physical separation and electrical isolation between redundant portions of the RPS is provided by separated process instrumentation, separated racks, and either separated or protected panels and cabling.

Separate SSLC panels for RPS logic are provided for each division except for the MCR main console, which has internal metal barriers. Where equipment from more than one division is in a panel, divisional separation is provided by fire barriers and/or physical distance of 15.2 cm or more where practicable. Where wiring must be run between redundant divisions, divisional separation is provided by electronic optical isolators or by fiber optic cables.

The ability of the RPS to withstand a safe shutdown earthquake is discussed in Subsection 7.2.1.2.

The ability of the RPS to function properly with a single failure is discussed in Subsection 7.2.1.2.

The ability of the RPS to function properly while any one sensor or channel is bypassed or undergoing test or maintenance is discussed in Subsection 7.2.1.2.

The RPS logic circuit is designed so that an automatic scram will be initiated when the required number of sensors for any monitored variable exceeds the scram setpoint.

Separate racks are provided for the RPS instrumentation for each division and are installed in different locations.

(8) Design Basis 7.1.2.2(1)(o) and (p)

Access to trip settings, component calibration controls, test points, and other terminal points is under the control of plant operations supervisory personnel.

Manual bypass of I&C equipment components is under the control of the operator in the MCR. If the ability to trip some essential part of the system is bypassed, this fact is continuously annunciated in the MCR. Operating bypasses are removed by normal reactor operation and need not be annunciated.

For the subsystem operational bypasses (Subsection 7.2.1), bypassing of these subsystem components provides a continuous annunciation in the MCR. If other components are bypassed, such as taking a sensor out of service for calibration or testing, this condition will also be annunciated continuously in the MCR through the administratively controlled manual actuation of the RPS out-of-service annunciator associated with that sensor.

7.2.2.1.1 Other Design Basis Requirements

The environment in which the instruments and equipment of the RPS must operate is given in Section 3.11.

The MCR maximum environment is predicated on supplying the MCR with minimum outside air for recirculated conditioned air. The minimum environment is predicated on a mixture of outside and recirculated air concurrent with minimum equipment heat loss. Components that monitor RPS trip initiating conditions that must function in the environment resulting from a RCPB break inside the drywell include, (1) are the condensing chambers, (2) inboard MSIV position switches, (3) NMS cabling, (4) reactor vessel pressure taps, (5) reactor vessel water level instrument taps, (6) sensing lines, and (7) drywell pressure taps. Special precautions are taken to ensure their operability after the accident. The condensing chambers and all essential components of the control and electrical equipment are either similar to those that have successfully undergone qualification testing in connection with other projects or additional qualification testing under simulated environmental conditions has been conducted.

The number of operable channels for the essential monitored variables is given in Table 7.2-2. The minimums apply to any untripped trip system. A tripped trip system may have any number of inoperative channels. Because reactor protection requirements vary with the mode in which the reactor operates, the table shows different functional requirements for the RUN and STARTUP modes. These are the only modes where more than one control rod can be withdrawn from the fully inserted position.

In case of a loss-of-coolant accident, reactor shutdown occurs immediately following the accident as process variables exceed their specified setpoint. Operator verification that shutdown has occurred may be made by observing one or more of the following indications:

- (1) Control rod status displays indicating each rod fully inserted.
- (2) Control rod scram valve status displays indicating open valves.
- (3) Neutron monitoring channels indicating decreasing neutron flux.

Following generator load rejection, a number of events occur in the following chronological order:

- (4) The pressure in the hydraulic oil lines to the control valves drops and pressure sensors signal the RPS to scram. At the same time, the turbine logic pressure controller initiates fast opening of the turbine bypass valves to minimize the pressure transient. Turbine stop valve closure and turbine control valve fast closure initiates the recirculation pump trip (RPT) logic, which trips the recirculation pumps at power levels greater than 40% unless the required number of turbine bypass valves open to their 10% position within a time delay period.
- (5) The reactor will not scram if the required number of bypass valves open to their 10% position within a time delay period. Otherwise, the reactor will scram unless the unit load is less than some preselected value (typically 40%), below which the control valve fast closure pressure transient does not threaten the fuel thermal limits.
- (6) The trip setting of the APRM channels will be automatically reduced as recirculation flow decreases (flow referenced scram). Power level will have been reduced by a reactor scram and RPT initiation.

The trip settings discussed in Subsection 7.2.1 are not changed to accommodate abnormal operating conditions. Actions required during abnormal conditions are discussed in plant abnormal operating procedures. Transients requiring activation of the RPS are discussed in Chapter 15. The discussions there designate which system and instrumentation are required to mitigate the consequences of these transients.

7.2.2.1.2 Other Considerations

Operability of the anticipatory signals from the turbine control valve fast closure or turbine stop valve closure following a safe shutdown earthquake is not a system design basis. As discussed in Subsection 5.2.2.2.2.2, closure of all the MSIVs without MSIV position sensor trip produces a similar effect which is slightly more severe. The design basis analysis is conducted for the MSIV closure.

7.2.2.2 Conformance to Regulatory Codes, Guides, and Standards

7.2.2.2.1 Regulatory Guides

- (1) Regulatory Guide 1.22—Periodic Testing of Protection System Actuation Functions*

The system is designed so that it may be tested during plant operation from sensor device to final actuator device. The test must be performed in overlapping portions so that an actual reactor scram will not occur as a result of the testing.

- (2) Regulatory Guide 1.47—Bypassed and Inoperable Status Indication for Nuclear Power Plant Safety Systems.

Automatic indication is provided in the MCR to inform the operator that the system is out of service. Displays indicate which part of a system is not operable.

Regulatory Position C.4

All the annunciators can be tested by depressing the annunciator test switches in the MCR.

The following discussion expands the explanation of conformance to Regulatory Guide 1.47 to reflect the importance of providing accurate information for the operator and reducing the possibility for the indicator equipment to adversely affect its monitored safety system.

- (a) Displays are arranged on the main control console and wide display to indicate which function of the system is out of service, bypassed, or otherwise inoperable. The automatic displays remain lit and cannot be cleared until the function is operable. All bypass and inoperability displays, both at a system level and component level, are grouped if possible with controls and displays that could prevent a system from operating if needed.
- (b) A manual switch is provided for manual actuation to cover out-of-service conditions which could not be automatically annunciated.
- (c) These display provisions serve to supplement administrative controls and aid the operator in assessing the availability of component and system level protective actions. These displays do not perform a safety function.
- (d) All system out-of-service annunciator circuits are electrically independent of the plant safety systems to prevent the possibility of adverse effects.

* Includes conformance with BTP-HICB-8.

(e) Testing of displays will be performed on a periodic basis, when equipment associated with the display is tested.

- (3) Regulatory Guide 1.53—Application of the Single-Failure Criterion to Nuclear Power Plant Protection Systems.

Compliance with NRC Regulatory Guide 1.53 is met by specifying, designing, and constructing the Reactor Protection System to meet the single-failure criterion described in Section 4.2 of IEEE-279 (Criteria for Protection Systems for Nuclear Power Generating Stations) and IEEE-379 (Standard Application of the Single-Failure Criterion to Nuclear Power Generating Station Class 1E Systems). Redundant sensors are used and the logic is arranged to ensure that a failure in a sensing element or the decision logic or an actuator will not prevent protective action. Separated channels are employed so that a fault affecting one channel will not prevent the other channels from operating properly. A complete discussion of the RPS power supplies is presented in Subsection 7.2.1.1.

- (4) Regulatory Guide 1.62—Manual Initiation of Protective Actions.

Means are provided for manual initiation of reactor scram through the use of two armed pushbutton switches and the reactor mode switch. Operation of both pushbutton switches or placing the mode switch in the “SHUTDOWN” position accomplishes the reactor scram. These switches are located on the principal MCR console.

The amount of equipment common to initiation of both manual scram and automatic scram is limited to actuated load power sources, actuated loads and cabling between the two. There is no shared trip or scram logic equipment for manual scram and automatic scram. No single failure in the manual, automatic, or common portions of the protection system will prevent initiation of reactor scram by manual or automatic means.

Manual initiation of reactor scram, once initiated, goes to completion as required by IEEE-279, Section 4.16.

- (5) Regulatory Guide 1.75—Physical Independence of Electric Systems

The RPS complies with the criteria set forth in IEEE-279, Paragraph 4.6, and Regulatory Guide 1.75, which endorses IEEE-384. Class 1E circuits and Class 1E-associated circuits are identified and separated from redundant and non-Class 1E circuits. Isolation devices are provided in the design where an interface exists between redundant Class 1E divisions and between non-Class 1E and Class 1E or Class 1E-associated circuits. Independence and separation of safety-related systems is discussed in Subsections 8.3.1.3 and 8.3.1.4.

Physical and electrical independence of the instrumentation devices of the system is provided by channel independence for sensors exposed to each process variable. Separate and independent raceways are routed from each device to the respective remote multiplexing units (RMUs). Each channel has a separate and independent MCR panel. Trip logic outputs are separated in the same manner as are the channels. Signals between redundant RPS divisions are electrically and physically isolated by Class 1E isolators or by fiber optic cables.

- (6) Regulatory Guide 1.105—Refer to Subsection 7.1.2.11.9 for assessment of Regulatory Guide 1.105.
- (7) Regulatory Guide 1.118—Refer to Subsection 7.1.2.11.10 for assessment of Regulatory Guide 1.118.

Regulatory Position C.5 for APRM

With respect to conformance to Position C.5, the inherent time response of the incore sensors used for APRM (fission detectors operating in the ionization chamber mode) is many orders of magnitude faster than the APRM channel response time requirements and the signal conditioning electronics. The sensors cannot be tested without disconnecting and reconnecting to special equipment.

- (8) Regulatory Guide 1.152 - Criteria for Digital Computers in Safety Systems of Nuclear Power Plants.

The hardware and software within SSLC for the RPS function and other safety systems are developed in compliance with this Reg Guide, which endorses IEEE Std. 7-4.3.2. The structured development plan for SSLC controllers includes conformance to all software standards referenced in IEEE Std. 7-4.3.2-1993. Hardware and software are integrated into a final assembly that is validated by testing against input requirements.

- (9) Regulatory Guide 1.153 - Criteria for Power, Instrumentation, and Control Portions of Safety Systems.

The configuration of SSLC regarding independence, separation, and the single-failure criterion for the RPS function and other safety systems conforms to the requirements of this Reg Guide which endorses IEEE-Std. 603.

7.2.2.2.2 Conformance to 10CFR50 Appendix A, General Design Criteria

- (1) Criterion 2—Protection against Natural Phenomena

Wind and tornado loadings are discussed in Section 3.11, flood design in Section 3.4, and seismic qualification of instrumentation and electrical equipment in Section 3.10.

(2) Criterion 4—Environmental and Missile Design Bases

The RPS is designed to assure that the effects of natural phenomena and of normal operation, maintenance, testing and postulated accident conditions on redundant channels, divisions and equipment of the RPS will not result in the loss of the safety function of the system.

The redundant divisions of RPS/SSLC are electrically and physically separated from each other such that (1) no design basis event is capable of damaging equipment in more than one division and (2) no single failure, test, calibration or maintenance operation can prevent the safety function of more than one division.

(3) Criterion 13—Instrumentation and Control

Instrumentation is provided to monitor variables and systems over their respective anticipated ranges for normal operational, anticipated operational occurrences, and accident conditions to assure adequate safety. Each system input is monitored and annunciated.

(4) Criterion 19—Control Room

The MCR is designed in accordance with this criterion. The design basis is provided in Section 1.2. If necessary, a reactor scram can be initiated from outside the MCR by opening the circuit breakers in the A and B scram solenoid power distribution circuits. After scram initiation, capability for hot shutdown and subsequent cold shutdown from remote locations is provided by the Remote Shutdown System (Subsection 7.4.1.4). These functions are not within the scope of the RPS.

(5) Criterion 20—Protection System Functions

The system constantly monitors the appropriate plant variables to maintain the fuel barrier and primary coolant pressure boundary and initiates a scram automatically when the variables exceed the established setpoints.

(6) Criterion 21—Protection System Reliability and Testability

RPS/SSLC is designed with four redundant instrument channels and four independent and separated output channels. No single failure can prevent a scram. Individual components and select groups of components can be tested during plant operation to assure equipment and system reliability.

(7) Criterion 22—Protection System Independence

The redundant portions of the system are separated so that no single failure or credible natural disaster can prevent a scram except the turbine scram inputs which originate from the non-seismic Turbine Building. Reactor pressure and power are diverse to the turbine scram variables. In addition, drywell pressure and water level are diverse variables.

(8) Criterion 23—Protection System Failure Modes

The system is fail-safe on loss of power, in that loss of electrical power or air supply will not prevent a scram. Postulated adverse environments will not prevent a scram.

(9) Criterion 24—Separation of Protection and Control Systems

The system has no control function. It has interlocks with control systems through isolation devices. For each interlock with a control system, separate signals are provided by redundant portions of SSLC.

(10) Criterion 25—Protection Control System Redundancy and Capability

The RPS conforms to the requirements of GDC 25. The method of conformance is as follows:

The redundant portions of the system are designed such that no single failure can prevent a scram. Functional diversity is employed by measuring flux, pressure, and level in the reactor vessel, which are all reactivity-dependent variables.

The RPS provides protection against the onset and consequences of conditions that threaten the integrity of the fuel barrier and the reactor coolant pressure boundary. Any monitored variable which exceeds the scram setpoint will initiate an automatic scram and not impair the remaining variables from being monitored (i.e., if one channel fails, the remaining portions of the RPS will function).

(11) Criterion 29—Protection Against Anticipated Operational Occurrences

The system will initiate a reactor scram in the event of anticipated operational occurrences.

7.2.2.2.3 Conformance to Industry Codes and Standards

7.2.2.2.3.1 IEEE-279, Protection Systems for Nuclear Power Generating Stations

The Reactor Protection System and its supporting SSLC functions conform to the requirements of this standard. The following is a detailed discussion of this conformance.

(1) General Functional Requirement (Paragraph 4.1)

The entire RPS, including its SSLC logic, trip actuator logic, and trip actuators, is designed to comply with this requirement through automatic removal of electric power to the CRD scram pilot valve solenoids when a sufficient number of RPS variables exceeds the specified trip setpoint.

(2) Single—Failure Criterion (Paragraph 4.2)

The RPS has four completely separate divisions with separate sensors whose only interaction is at the trip logic level via optical isolation. The system is in full compliance with the single-failure criterion and Regulatory Guide 1.53 (Subsection 7.2.2.2.1(3)).

(3) Quality of Components and Modules (Paragraph 4.3)

All RPS and SSLC components and modules and such safety-related equipment of other systems providing inputs to the RPS are designed to maintain necessary functional capability under the extremes of conditions (as applicable), relating to environment energy supply, malfunctions, and accidents, within which the equipment has been designed and qualified to operate continuously and without degradation.

(4) Equipment Qualification (Paragraph 4.4)

Instrument sensors and electrical components of the RPS and interfacing systems which are used for RPS functions are qualified for nuclear safety-related service (important to safety) for the function times and for the environmental zones in which they are located. The RPS electrical Class 1E equipment, including the SSLC controllers and cabinets, is qualified by type test data, previous operating experience or analysis, or any combination of these three methods to substantiate that all equipment which must operate to provide the safety system actions will be capable of meeting, on a continuing basis, the necessary performance requirements.

(5) Channel Integrity (Paragraph 4.5)

All RPS instrument channels, components, supporting SSLC equipment, and such safety-related equipment of other systems providing inputs to the RPS are designed to maintain necessary functional capability under the extremes of conditions (as

applicable), relating to environment energy supply, malfunctions, and accidents, within which the equipment has been designed and qualified to operate continuously and without degradation.

(6) Channel Independence (Paragraph 4.6)

The RPS and supporting SSLC equipment are designed to assure that the effects of natural phenomena and of normal operation, maintenance, testing and postulated accident conditions on redundant channels, divisions and equipment of the RPS will not result in the loss of the safety function of the system.

The redundant divisions of RPS/SSLC are electrically and physically separated from each other such that (1) no design basis event is capable of damaging equipment in more than one division and (2) no single failure, test, calibration or maintenance operation can prevent the safety function of more than one division.

Instrument channels that provide signals for the same protective function are independent and physically separated to accomplish the decoupling of the effects of unsafe environmental factors, electric transients and physical accident consequences and to reduce the likelihood of interactions between channels during maintenance operations or in the event of channel malfunctions.

(7) Control and Protection System Interaction (Paragraph 4.7)

The channels for the RPS trip variables are electrically isolated and physically separated from the plant control systems in compliance with this design requirement.

Multiple redundant sensors and channels assure that no single failure can prevent protective action.

Multiple failures resulting from a single credible event could cause a control system action (closure of the turbine stop or control valves) resulting in a condition requiring protective action and concurrent prevention of operation of a portion of the RPS (scram signal from the turbine stop or control valves) [Subsection 7.2.1.1.5.2(6)]. The reactor vessel high-pressure and high-power trips provide diverse protection for this event.

(8) Derivation of System Inputs (Paragraph 4.8)

The following RPS trip variables are direct measures of a reactor overpressure condition, a reactor overpower condition, a reactor instability condition, a gross fuel damage condition, or abnormal conditions within the reactor coolant pressure boundary:

(a) Reactor vessel low water level trip

- (b) Neutron monitoring (APRM/OPRM) system trip
 - (i) Neutron flux trip
 - (ii) Simulated thermal power
 - (iii) Channel inoperative
- (c) Neutron Monitoring (SRNM) System trip
 - (i) Neutron flux trip
 - (ii) Short neutron flux period
 - (iii) Channel inoperative
- (d) Drywell high pressure trip
- (e) Reactor vessel high pressure trip

Other variables that could affect the RPS scram function itself, are thus monitored to induce scram directly include:

- (f) Low charging pressure to control rod HCU accumulators
- (g) High suppression pool temperature
- (h) High seismic acceleration in Reactor Building

The detection of MSIV position and turbine stop valve position is an appropriate variable for the Reactor Protection System. The desired variable is loss of the reactor heat sink; however, isolation or stop valve closure is the logical variable to inform that the steam path has been blocked between the reactor and the heat sink.

Due to the normal throttling action of the turbine control valves with changes in the plant power level, measurement of control valve position is not an appropriate variable from which to infer the desired variable, which is rapid loss of the reactor heat sink. Consequently, a measurement related to control valve closure rate is necessary.

Protection system design practice has discouraged use of rate-sensing devices for protective purposes. In this instance, it was determined that detection of hydraulic actuator operation would be a more positive means of determining fast closure of the control valves.

Loss of hydraulic pressure in the electrohydraulic control (EHC) oil lines, which initiates fast closure of the control valves, is monitored. These measurements provide indication that fast closure of the control valves is imminent.

This measurement is adequate and is a proper variable for the protective function, taking into consideration the reliability of the chosen sensors relative to other

available sensors and the difficulty in making direct measurements of control valve fast-closure rate.

The turbine stop valve closure trip bypass and control valve fast closure trip operating bypass permit continued reactor operation at low-power levels when the turbine stop or control valves are closed. The selection of turbine first-stage pressure is an appropriate variable for permissive of this bypass function. In the power range of reactor operation, turbine first-stage pressure is essentially linear with increasing reactor power. Consequently, this variable provides the desired measurement of power level (i.e., whenever turbine first-stage pressure is below a specified value, the valve closure trip signals are automatically bypassed).

(9) Capability for Sensor Checks (Paragraph 4.9)

The RPS fully meets this requirement in that it conforms with Regulatory Guides 1.118 and 1.22. The four-channel SSLC logic allows cross-checking between channels and the ability to take any one channel out of service. When a channel is taken out of service, this fact is annunciated and the two-out-of-four logic reverts to two-out-of-three.

(10) Capability for Test and Calibration (Paragraph 4.10)

The RPS and SSLC fully meet this requirement in that they conform with Regulatory Guides 1.22 and 1.118. Capability for test and calibration is similar to that of sensor checks in that the four-channel SSLC logic allows cross-checking between channels and the ability to take any one channel out of service during reactor operation. Such a condition is annunciated and automatically causes the channel trip logic to revert from two-out-of-four to two-out-of-three.

Most sensors have a provision for actual testing and calibration during reactor operation. The exceptions are defined as follows:

- (a) During plant operation, the operator can confirm that the MSIV and turbine stop valve limit switches operate during valve motion. Precise calibration of these sensors requires reactor shutdown.
- (b) Independent functional testing of the air header dump valves can be performed during each refueling outage. In addition, operation of at least one valve can be confirmed following each scram occurrence. These requirements are discussed in Chapter 16.

(11) Channel Bypass or Removal from Operation (Paragraph 4.11)

The two-out-of-four logic within SSLC for RPS is designed such that an entire division or its channel trip signals (except the NMS related trip functions and the

manual reactor trip functions) can be bypassed to prevent initiation of protective action as a result of maintenance, testing or calibration operations.

An instrument channel bypass may be accomplished by SSLC bypass switches provided for each divisional channel of the RPS.

Placing a channel-of- sensors bypass switch in its BYPASS position manually reduces the normal coincident channel for reactor trip from two-out-of-four (2/4) to two-out-of-three (2/3) in all four divisions. The coincident channel- trip logic cannot be reduced further than 2/3, as only one sensor channel is capable of being bypassed at any one time. The bypass condition is automatically annunciated for the individual channel being bypassed.

A division trip logic bypass may be accomplished by SSLC bypass switches provided for each division of RPS logic. Placing a trip logic bypass switch in BYPASS manually reduces the normal scram logic to a coincidence of two-out-of-three tripped divisions. The coincident scram logic cannot be reduced further than two-out-of-three, as only one division is capable of being bypassed at any one time. The bypass condition is automatically annunciated for the individual division being bypassed.

Transmitters are normally tested during reactor operation by cross-comparison of channels. However, transmitters and other sensors may be valved out of service and returned to service under administrative control procedures. Since only one sensor is valved out of service at any given time during the test interval, protective capability for the RPS trip variables is maintained through the remaining redundant instrument channels.

(12) Operating Bypasses (Paragraph 4.12)

The following RPS trip variables have no provision for an operating bypass:

- (a) Reactor vessel low water level trip
- (b) Neutron monitoring (APRM/OPRM system trip)
- (c) High seismic activity
- (d) Drywell high-pressure trip
- (e) Reactor vessel high-pressure trip
- (f) High suppression pool temperature

An operating bypass of the low HCU accumulator charging pressure trip is provided in the MCR for the operator to bypass the trip outputs during SHUTDOWN and REFUEL modes of operation. Control of this bypass is achieved with bypass

switches through administrative means. Its only purpose is to permit reset of the RPS following reactor scram because the low charging water pressure condition would persist until the scram valves are re-closed. The bypass is manually initiated and must be manually removed (via switches or placing the mode switch in STARTUP) to commence withdrawal of control rods after a reactor shutdown.

An operating bypass is provided for the MSIV closure trip. The bypass requires that the reactor mode switch, which is under the administrative control of the operator, be placed in the SHUTDOWN, REFUEL, or STARTUP positions. The only purpose of this bypass is to permit the RPS to be placed in its normal energized state for operation at low-power levels with the MSIVs closed or not fully open.

An operating bypass is provided for the SRNM trip when the reactor mode switch is placed in the RUN position.

For each of these operating bypasses, separate signals are provided from the mode switch to each division of RPS logic in SSLC to assure that all of the protection system criteria are satisfied.

An operating bypass of the turbine stop valve and control valve fast closure trip is provided whenever the turbine is operating at a low initial power level (i.e., with the mode switch in SHUTDOWN, REFUEL, or STARTUP positions). The purpose of the bypass is to permit the RPS to be placed in its normal energized state for operation at low-power levels with the turbine stop valves not fully open.

Special provision has been made to effect bypass of any one of the four MSIV closure RPS trip channels. This permits flexibility for testing and allows continued reduced power operation in the event of possible malfunction of the MSIVs such that up to two of the four steamlines can be closed off, for test purposes or otherwise, without resulting in a full reactor scram condition, provided the load has been reduced to limit reactor pressure and steam flow. The remaining three main steamlines automatically revert to two-out-of-three logic such that closure of a second MSIV will result in a "half-scram" condition. This special bypass of any one channel will be automatically removed if a sensor channel bypass (described in Subsection 7.2.2.2.3.1(11) is imposed on any other channel.

In general, whenever the applicable conditions for instrumentation scram bypasses are not met, the RPS shall automatically accomplish one of the following:

- (a) Prevent the actuation of an operating bypass.

- (b) Remove any active operating bypass.
- (c) Obtain or retain the permissive conditions for the operating bypass.
- (d) Initiate the protective function.

(13) Indication of Bypasses (Paragraph 4.13)

The mode changes produced by operating bypasses need not be annunciated because they are removed by normal reactor operating sequence.

Although operating bypasses do not require annunciation, certain operating bypasses are annunciated in the MCR. The CRD HCU accumulator low charging water pressure trip operating bypass, the MSIV closure trip operating bypass, the turbine stop and control valve fast closure trips operating bypass, and the division-of-sensors bypass are individually annunciated to the operator. Individual SRNM and APRM instrument channel bypasses are indicated on displays for each division on the MCR panels.

(14) Access to Means for Bypassing (Paragraph 4.14)

All instrumentation valves associated with the individual RPS trip and bypass sensors are either locked open or locked closed, depending upon their normal state. The operator has administrative control of the sensor instruments and valves.

All manual bypasses (previously discussed) are controlled by keylock switches under administrative control of the operator. The mode switch itself is keylock operative, since its position affects the operating bypass logic.

(15) Multiple Setpoints (Paragraph 4.15)

All RPS trip variables are fixed except for the following, which are individually addressed.

The trip setpoint of each SRNM channel is generally fixed. However, there is also the scram initiated by intermediate high neutron flux level corresponding to $5E + 5$ counts per second. This is only activated in a non-coincidence scram mode by a switch in the RPS SSLC cabinet. The conditions under which such trip is to be activated are included in plant operating procedures.

In the RUN mode, the APRM system simulated thermal-power trip varies automatically with recirculation flow (Section 7.6).

In modes other than RUN, the APRM setdown function automatically selects a more restrictive scram trip setpoint at a fixed 15%. The devices used to prevent improper

use of the less restrictive setpoints are designed in accordance with criteria regarding performance and reliability of protection system equipment.

Operation of the mode switch from one position to another bypasses various RPS trips and channels and automatically alters NMS trip setpoints in accordance with the reactor conditions implied by the given position of the mode switch. All equipment associated with these setpoint changes are considered part of the protection system and are qualified Class 1E components.

(16) Completion of Protective Action after Initiation (Paragraph 4.16)

It is only necessary that the process sensors remain in a tripped condition for a sufficient length of time to trip the digital trip modules and operate the seal-in circuitry, provided the two-out-of-four logic is satisfied. Once this action is accomplished, the trip actuator logic proceeds to initiate reactor scram regardless of the state of the process sensors that initiated the sequence of events. The same holds true for the manual scram pushbuttons.

(17) Manual Actuation (Paragraph 4.17)

Two manual scram pushbutton controls are provided on the principal MCR console to permit manual initiation of reactor scram at the system level. Both switches must be depressed to initiate a scram. Backup to these manual controls is provided by the SHUTDOWN position of the reactor system mode switch. Failure of the manual scram portion of the RPS cannot prevent the automatic initiation of protective action, nor can failure of an automatic RPS function prevent the manual portions of the system from initiating the protective action.

No single failure in the manual or automatic portions of the system can prevent either a manual or automatic scram.

(18) Access to Setpoint Adjustments, Calibration, and Test Points (Paragraph 4.18)

The RPS/SSLC design permits the administrative control of access to all setpoint adjustments, module calibration adjustments and test points. These administrative controls are supported by provisions within the safety system design, by provisions in the generating station design, or by a combination of both.

(19) Identification of Protective Actions (Paragraph 4.19)

When any one of the redundant sensor trip modules exceeds its setpoint value for the RPS trip variables, a MCR annunciator is initiated to identify the particular variable. In the case of NMS trips to the RPS, the specific variable or variables that exceed setpoint values are identified as a function of the NMS.

Identification of the particular trip channel exceeding its setpoint is accomplished as a typed record from the process computer system.

When any manual scram pushbutton is depressed, a MCR annunciation is initiated and a plant computer system record is produced to identify the tripped RPS trip logic.

Identification of the mode switch in shutdown position scram trip (and trip bypass) is provided by the plant computer system trip logic identification printout, the mode switch in shutdown position annunciator, and all division trips.

(20) Information Readout (Paragraph 4.20)

The data presented to the MCR operator is consistent with human factors criteria and complies with this design requirement (Chapter 18). The safety system logic and control system (SSLC), which incorporates the RPS, is designed with self-test features which enhance the operator's awareness of the system itself. Each division and interdivisional function is tested sequentially and repetitively.

(21) System Repair (Paragraph 4.21)

Generally, all components can be replaced, repaired, and adjusted during operation. Exceptions are listed below.

During periodic testing of the sensor channels for the following trip variables, all defective components can be identified. Replacement and repair of failed sensors can only be accomplished during reactor shutdown.

- (a) Neutron Monitoring System detectors
- (b) Turbine control valve fast closure sensors
- (c) MSIV closure sensors
- (d) Turbine stop valve closure sensors

Provisions have been made to facilitate repair of NMS components during plant operation except for the detectors. Replacement of the detectors can be accomplished during shutdown.

(22) Identification of Protection Systems (Paragraph 4.22)

The RPS logic is housed, along with that of the essential core cooling systems and the leak detection and isolation systems, in the safety system logic and control (SSLC) cabinets. There are four distinct and separate cabinets in accordance with the four electrical divisions. Each division is uniquely identified by color code including cables and associated cables. The SSLC cabinets themselves are clearly marked with the words "Safety System Logic and Control". Each of the safety systems controlled

is clearly identified on the cabinets in accordance with their system grouping and labeling. MCR panels are identified by tags on the panels which indicate the function and identify the contained logic channels. Redundant racks are identified by the identification marker plates of instruments on the racks.

7.2.2.2.3.2 Conformance to Other IEEE Standards

- (1) IEEE-323—Standard for Qualifying Class 1E Equipment for Nuclear Power Generating Stations

The general guide for qualifying Class 1E equipment is presented in Section 3.11. Records covering all essential components are maintained.

- (2) IEEE-344—Recommended Practices for Seismic Qualification of Class 1E Equipment for Nuclear Power Generating Stations

Seismic qualification of Class 1E equipment requirements are satisfied by all Class 1E RPS and SSLC equipment as described in Section 3.10.

7.2.2.2.4 Conformance to Branch Technical Positions

- (1) BTP-HICB-3: Guidance on Protection System Trip Point Changes for Operation with Reactor Coolant Pumps Out of Service

The RPS design conforms with this position in that setpoint changes to more restrictive values are accomplished automatically in conjunction with the mode switch position [Subsection 7.2.2.2.3.1(15)].

- (2) BTP-HICB-8: Guidance on Application of Regulatory Guide 1.22.

The RPS design conforms with this position, as discussed in Subsection 7.2.2.2.1(1).

- (3) BTP-HICB-9: Guidance on Reactor Protection System Anticipatory Trips

All hardware used to provide trip signals to the RPS is designed in accordance with IEEE-279 and is considered safety-related. This includes the sensors for turbine stop valve closure, turbine control valve fast closure, and turbine bypass valve position even though these are located in the non-seismic Turbine Building. Since reactor high pressure and power trips are diverse to the turbine scram variables, locating the sensors in the turbine enclosure does not compromise the ability of the RPS to provide protective action when required.

- (4) BTP-HICB-11: Application and qualification of Isolation Devices

The RPS design conforms with this position, as discussed in Subsection 7.1.2.13(1).

(5) BTP-HICB-12: Establishing and Maintaining Instrument Setpoints

The RPS trip setpoints will be consistent with the requirements of Regulatory Guide 1.105, as discussed in Subsection 7.1.2.11.9.

7.2.2.3 Additional Design Considerations Analyses

(1) Spurious Rod Withdrawals

Spurious control rod withdrawal will not normally cause a scram but may cause control rod withdrawal block rod block, as discussed in Section 7.7, and is not part of the RPS. A scram will occur, however, if the spurious control rod withdrawal causes the average flux to exceed the trip setpoint, or causes SRNM short period.

(2) Loss of Plant Instrument Air System

Loss of plant instrument air will cause gradual opening of the scram valves on the hydraulic control units which will insert all control rods. Full insertion will result as air pressure is lost at the scram valves.

(3) Loss of Cooling Water to Vital Equipment

Loss of cooling water will not directly affect the RPS.

(4) Plant Load Rejection

Electrical grid disturbances could cause a significant loss of load, which would initiate a turbine generator overspeed trip and control valve fast closure, which may result in a reactor scram. Ordinarily, a reactor scram would occur to anticipate an increase in reactor vessel pressure due to shutting off the path of steam flow to the turbine. However, in the Lungmen NPS, upon a full load rejection signal, the turbine control valves are fast closed by the turbine control system and the turbine bypass valves are fast opened. Recirculation flow is automatically reduced and the selected control rods run-in (SCRRI) function (electric run-in of selected FMCRDs) is initiated to reduce turbine bypass steam flow to the main condenser. When the turbine control valves have fast-closed, reactor trip signals are generated by the hydraulic pressure sensors located at the turbine control valves and transmitted to RPS. A time delay is applied to these signals. During this time delay, if the required number of bypass valves are opening as indicated by their 10% position sensors, reactor scram and recirculation pump trip (RPT) are inhibited. The time delay is chosen such that if the bypass valves fail to open, acceptable thermal limits are maintained.

The fuel temperature or pressure boundary thermal/hydraulic limits are not exceeded during this event (Chapter 15).

(5) Turbine Trip

Initiation of turbine trip by the turbine system closes the turbine stop valves, ordinarily initiating a reactor scram. The stop valve closure scram anticipates a reactor pressure or power scram due to turbine stop valves closure. However, for turbine trip in the Lungmen NPS, the control actions are similar to that above for full load rejection. Turbine stop valve position signals are sent to the RPS. If the bypass valves are opening as indicated by the 10% position sensors, reactor scram and RPT are inhibited. Recirculation flow reduction and SCRRRI are initiated. If the main turbine is tripped because of high condenser pressure, as indicated by condenser pressure sensor signals sent to the SSLC, reactor scram and RPT will initiate to shut off steam flow to the main condenser to protect the main turbine and to avoid the potential for rupturing the low pressure turbine casing.

The fuel temperature or pressure boundary thermal/hydraulic limits are not exceeded during these events (Chapter 15).

Table 7.2-1 Trip Sensor Response Time and Operating Range

Device and Trip Condition	Function	Normal Operating Range	Sensor Channel Response Time
<u>Pressure Transmitter</u> Reactor Vessel Pressure High	Limits the increase in positive reactivity on high reactor pressure	0-10.3 MPa	≤ 0.5 s
<u>Pressure Transmitter</u> Drywell Pressure High	Detects excessive loss of coolant	0 - 0.036 MPa	≤ 0.6 s
<u>Level Transmitter</u> Reactor Vessel Water Level Low (L3)	Avoids fuel damage on loss of coolant	-0.069 - 1.46 m H ₂ O	≤ 1.0 s
<u>Pressure Transmitter</u> CRD HCU Accumulator Charging Header Pressure Low	Detects inability to scram due to degraded header pressure	0 - 245.2 MPa	≤ 1.0 s
<u>Position Switch</u> MSIV Closure	Protects reactor from primary heat sink loss	Fully opened to fully closed	≤ 0.01 s
NMS Trips	Limits maximum reactor power	See NMS subsection 7.7.1.6 for details of SRNM, APRM and Core Flow Rapid Coastdown trips	
<u>Position Switch</u> Turbine Stop Valve Closure	Limits reactor power to avoid fuel damage on primary heat sink loss	Fully open to fully closed	≤ 0.01 s
<u>Pressure sensor</u> Turbine Control Valve Fast Closure	Limits reactor power to avoid fuel damage on primary heat sink loss	0 - 11 MPa	≤ 0.03 s
<u>Accelerometers</u> Seismic Accel High	Trips reactor during large earthquake	0 - 300 gal (1 gal = 1cm/s ²)	≤ 0.5 s
<u>Position Sensor</u> Turbine Bypass Valve Open	Trip Inhibit for Turbine Stop Valve Closure and Turbine Control Valve Closure	Open/Closed	≤ 0.03 s
<u>Temperature Transmitters</u> Suppression Pool Temperature High	Detects high temperature in the Suppression Pool	-1 to 110°C	Sensor Channel Response Time for Suppression Pool Temperature will be included in the FSAR

Table 7.2-2 Channels Required for Functional Performance of RPS

Channel Description	# Sensors
Neutron Monitoring System (APRM/OPRM)	4 averaged channels
Neutron Monitoring System (SRNM)	10
Nuclear System high pressure	4
Drywell high pressure	4
Reactor vessel low level	4
Low charging header pressure to CRD HCU accumulator	4
Main steamline isolation valve position	8
Turbine stop valve position	4
Turbine control valve fast closure	4
Turbine bypass valve position (trip permissive)	40 (10 groups of 4)
High suppression pool temperature	64
High seismic activity	12 (3 sets of 4)

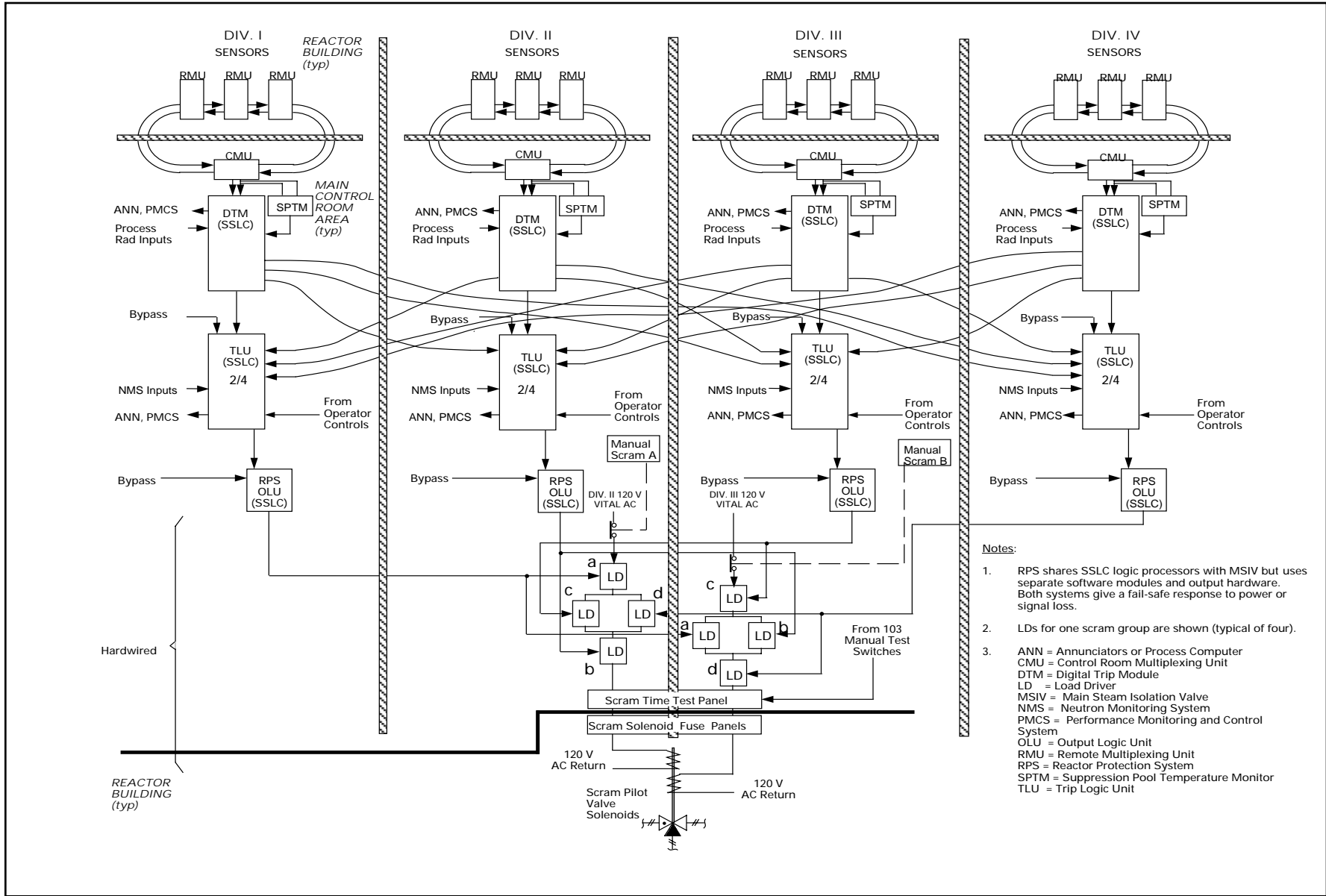

Figure 7.2-1 RPS Equipment Arrangement

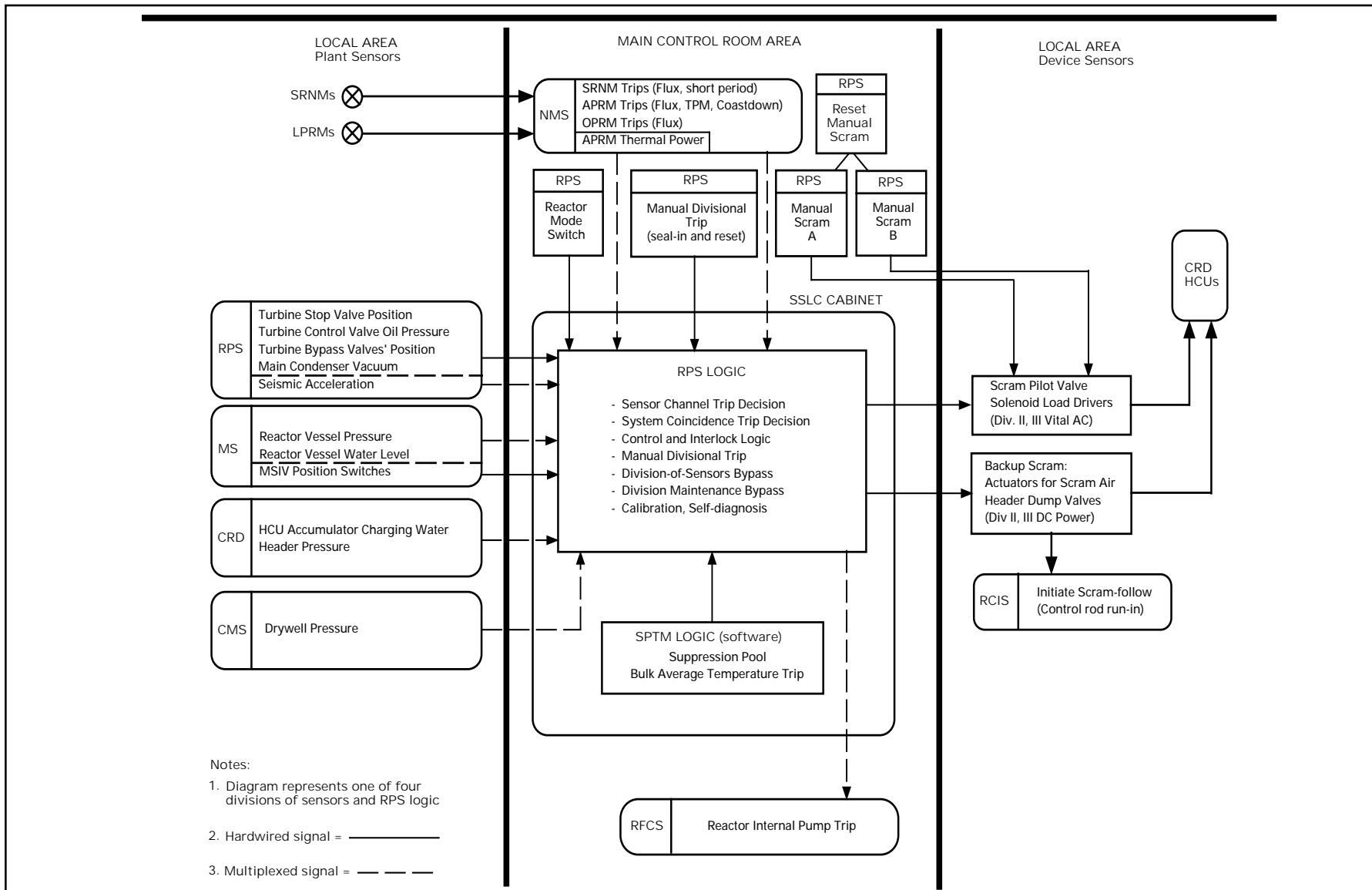

Figure 7.2-2 RPS Control Interface Diagram

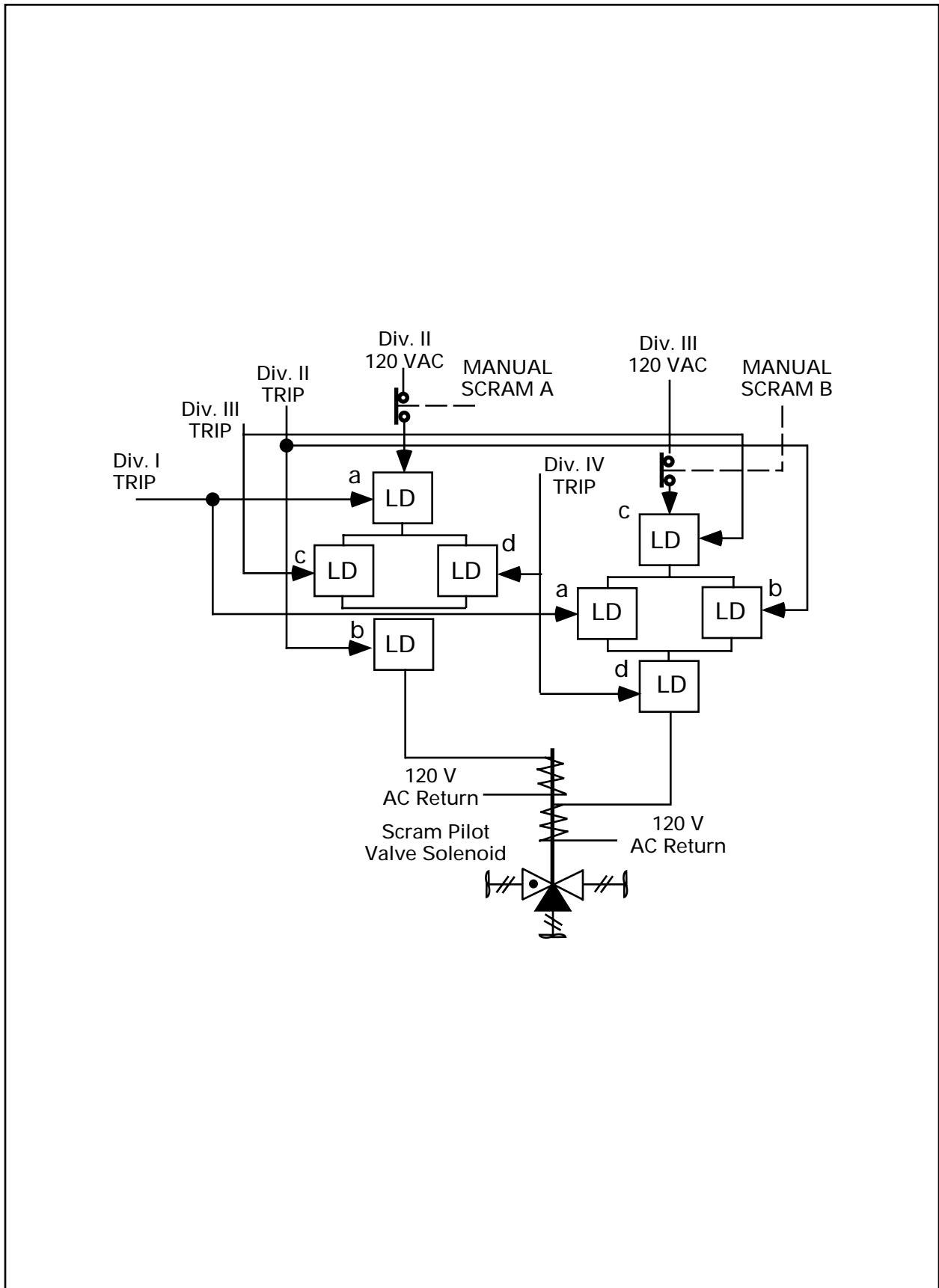

Figure 7.2-3 Scram Pilot Valve Solenoids Load Drivers Arrangement