

5.0 Reactor Coolant System and Connected Systems

5.1 Summary Description

The Reactor Coolant System (RCS) includes those systems and components which contain or transport fluids coming from or going to the reactor core. These systems form a major portion of the reactor coolant pressure boundary (RCPB). This chapter provides information regarding the RCS and pressure-containing appendages out to and including isolation valving. This grouping of components is defined as the RCPB.

RCPB includes all pressure-containing components such as pressure vessels, piping, pumps, and valves, which are:

- (1) Part of RCS.
- or
- (2) Connected to RCS up to and including any and all of the following:
 - (a) The outboard containment isolation valve in piping which penetrates the primary reactor containment.
 - (b) The second of the two valves normally closed during normal reactor operation in system piping which does not penetrate primary reactor containment.
 - (c) The RCS safety/relief valve (SRV) piping.

This chapter also deals with various subsystems which are closely allied to the RCPB (Section 5.4):

Pressure Relief System (PRS)

The nuclear Pressure Relief System (PRS) protects the RCPB from damage due to overpressure by providing pressure-operated relief valves that can discharge steam from the nuclear system to the suppression pool. PRS also acts to automatically depressurize the nuclear system in the event of a loss-of-coolant accident (LOCA) in which the Feedwater System (FW), Reactor Core Isolation Cooling System (RCIC) and High Pressure Core Flooder System (HPCF) fail to maintain reactor vessel water level. Depressurization of the nuclear system allows the low pressure flooder systems to supply enough cooling water to adequately cool the fuel.

Subsection 5.2.5 establishes the limits on nuclear system leakage inside the drywell so that appropriate action can be taken before the integrity of the nuclear system process barrier is impaired.

The reactor vessel and appurtenances are described in Section 5.3. The major safety consideration for the reactor vessel is the ability of the vessel to function as a radioactive material barrier. Various combinations of loading are considered in the vessel design. The

vessel meets the requirements of applicable codes and criteria. The possibility of brittle fracture was considered, and suitable design, material selection, material surveillance activity, and operational limits were established that avoid conditions where brittle fracture was possible.

Main Steam System (MS)

The Main Steam System (MS) accepts steam from the reactor pressure vessel (RPV). The steam flows through the RPV main steam outlet nozzle flow restrictors, the main steamlines, and the main steam isolation valves (MSIVs).

The main steamline flow restrictors of the venturi-type are included in each main steam nozzle on the reactor vessel inside the primary containment. The restrictors are designed to limit the rate of loss of coolant resulting from a main steamline break inside or outside the primary containment. The coolant loss is limited so that reactor vessel water level remains above the top of the core during the time required for the main steamline isolation valves to close. This action protects the fuel barrier.

Two MSIVs are installed on each main steamline. One is located inside and the other outside the primary containment. If a main steamline break occurs inside the containment, closure of the isolation valve outside the primary containment seals the primary containment itself. The MSIVs automatically isolate the RCPB when a pipe break occurs outside the containment. This action limits the loss of coolant and the release of radioactive materials from the nuclear system.

Feedwater System (FW)

The portion of the Feedwater System (FW) contained in the Control Building and the Reactor Building, provides a piping path for feedwater flow, Reactor Water Cleanup System (RWCU) return flow, and Residual Heat Removal System (RHR) and RCIC flows into the RPV. The portion of FW contained in the Turbine Building is described in Subsection 10.4.7.

Reactor Recirculation System (RCIR)

The Reactor Recirculation System (RCIR) provides coolant flow through the core. Adjustment of the core coolant flow rate changes reactor power output, thus providing a means of following plant load demand without adjusting control rods. RCIR is designed to provide a slow coastdown of flow so that fuel thermal limits cannot be exceeded as a result of recirculation system malfunctions. The reactor recirculation pumps are located inside the reactor vessel, thus eliminating large piping connections to the reactor vessel below the core and also eliminating the RCIR piping.

Reactor Core Isolation Cooling System (RCIC)

The Reactor Core Isolation Cooling System (RCIC) provides makeup water to the core during a reactor shutdown in which feedwater flow is not available. The system is started automatically upon receipt of a low reactor water level signal, high drywell pressure signal, or manually by the operator. Water is pumped to the core by a turbine pump driven by reactor steam.

Residual Heat Removal System (RHR)

The Residual Heat Removal System (RHR) includes a number of pumps and heat exchangers that can be used to cool the nuclear system under a variety of situations. During normal shutdown and reactor servicing, RHR removes residual and decay heat. RHR allows decay heat to be removed whenever the main heat sink (main condenser) is not available (i.e., hot standby). One mode of RHR operation allows the removal of heat from the primary containment following a LOCA. Another operational mode of RHR is low pressure floodler (LPFL).

The LPFL is an engineered safety feature for use during a postulated LOCA. Operation of the LPFL is presented in Section 6.3.

Reactor Water Cleanup System (RWCU)

The Reactor Water Cleanup System (RWCU) recirculates a portion of reactor coolant through a filter-demineralizer to remove particulate and dissolved impurities with their associated corrosion and fission products from the reactor coolant. It also removes excess coolant from the reactor system under controlled conditions.

5.1.1 Schematic Flow Diagrams

The schematic flow diagrams of RCS (Figures 5.1-1 and 5.1-2) show major components, principal pressures, temperatures, flow rates, and coolant volumes for normal steady-state operating conditions at rated power.

5.1.2 Piping and Instrumentation Diagrams (P&IDs)

Piping and instrumentation diagrams (P&IDs) covering the systems included within RCS and connected systems are presented as follows:

- (1) Main Steam System (MS) (Figure 5.1-3)
- (2) Feedwater System (FW) (Figure 5.1-4)
- (3) Reactor Recirculation System (RCIR) (Figure 5.4-4)
- (4) Reactor Core Isolation Cooling System (RCIC) (Figure 5.4-8)
- (5) Residual Heat Removal System (RHR) (Figure 5.4-10)
- (6) Reactor Water Cleanup System (RWCU) (Figure 5.4-12)

5.1.3 Elevation Drawings

The elevation drawings showing the principal dimensions of the reactor and connecting systems in relation to the containment are provided in Figures 1.2-2 and 1.2-3.

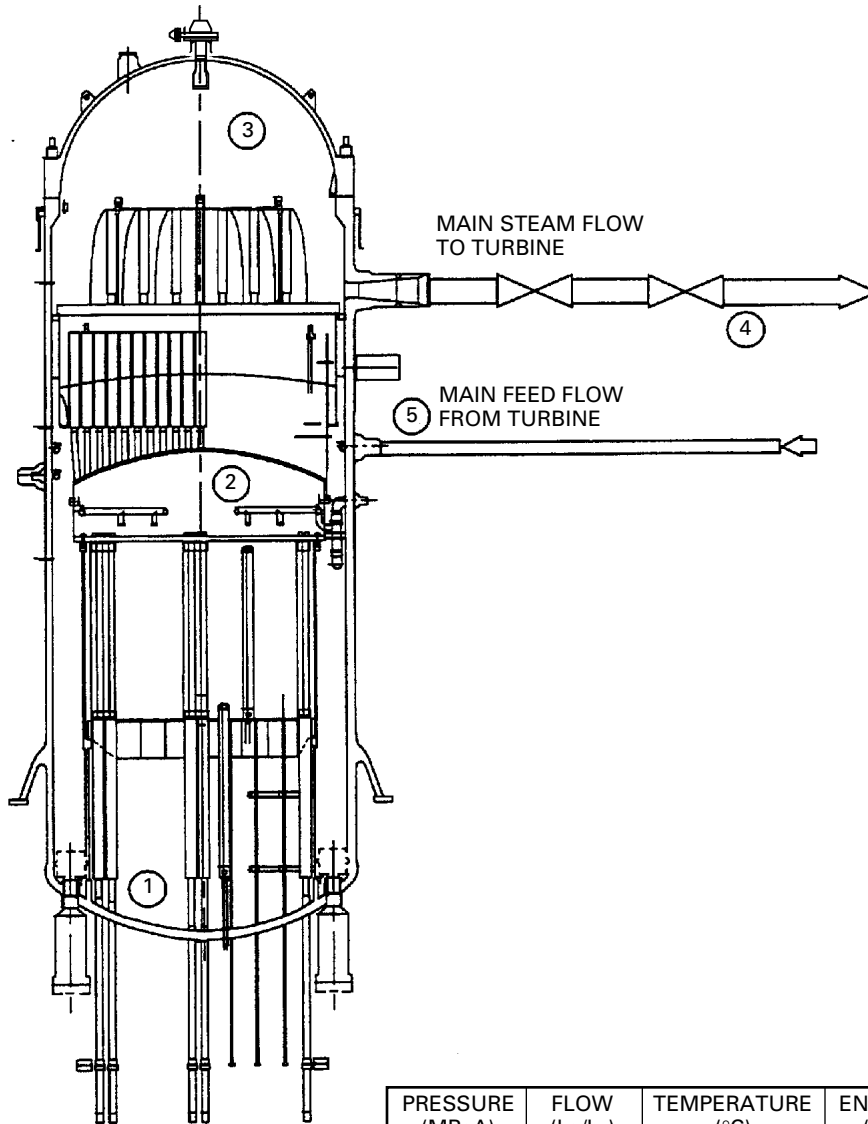

	PRESSURE (MPaA)	FLOW (kg/hr)	TEMPERATURE (°C)	ENTHALPY (kJ/kg)
1 CORE INLET	7.4*	52.2x10 ⁶ *	278*	1227*
2 CORE OUTLET	7.2*	52.2x10 ⁶ *	288*	1500*
3 SEPARATOR OUTLET (STEAM DOME)	7.2*	7.64x10 ⁶ *	287*	2770*
4 STEAMLINER (2ND ISOLATION VALVE)	6.9*	7.64x10 ⁶ *	285*	2770*
5 FEEDWATER INLET (INCLUDES CLEANUP RETURN FLOW)	7.3*	7.78x10 ⁶ *	216*	926*

* Estimated values. The final values to be provided in the FSAR

Figure 5.1-1 100% Rated Thermal Power Operating Conditions of the Lungmen ABWR

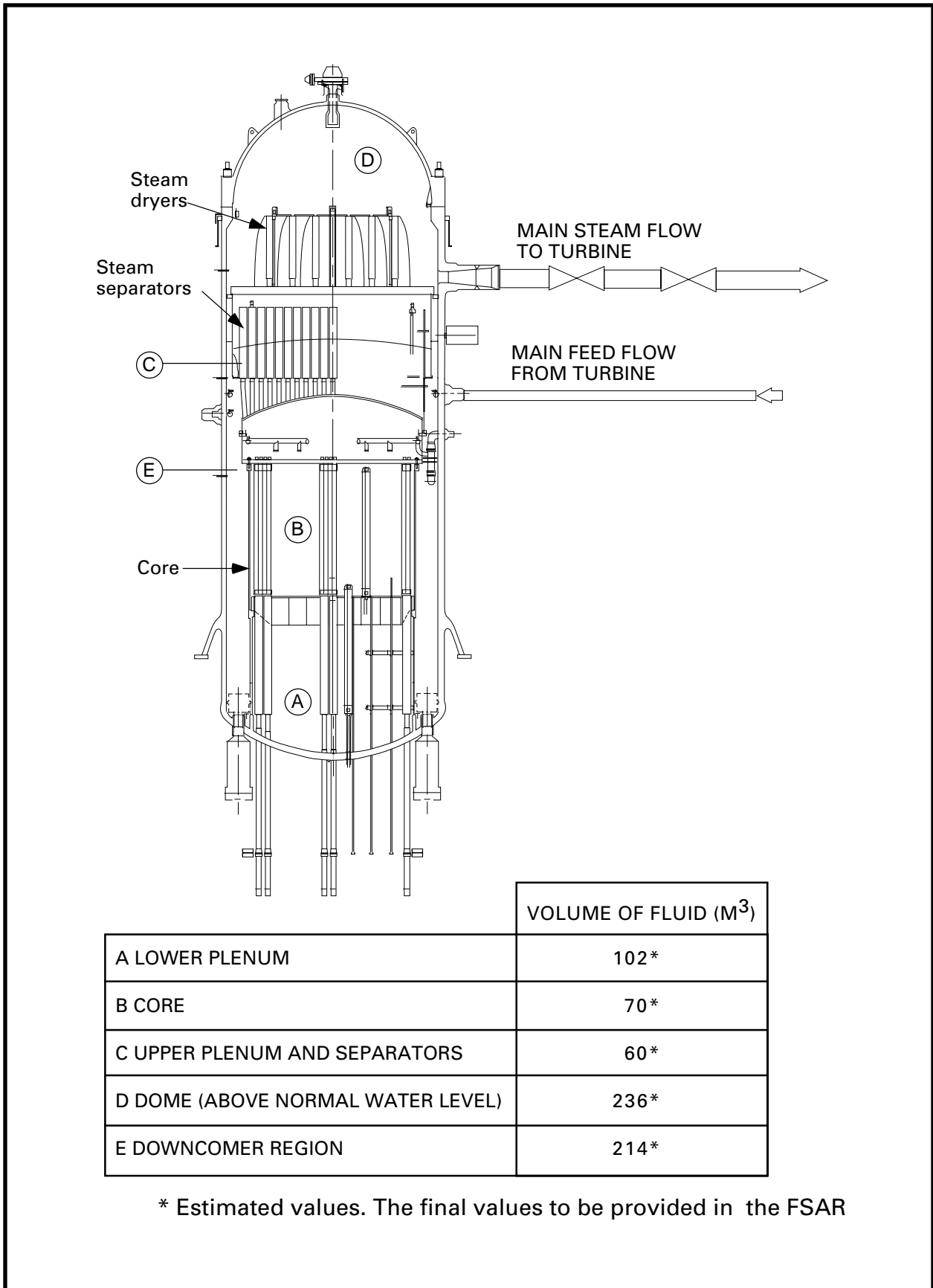

Figure 5.1-2 Coolant Volumes of the Lungmen ABWR

Figure 5.1-3 Main Steam System (MS) P&IDs (Sheets 1 through 7)

(Proprietary information provided in separate proprietary volume.)

Figure 5.1-4 Feedwater System (FW) P&ID

(Proprietary information provided in separate proprietary volume.)