

### **3.10 Seismic and Dynamic Qualification of Mechanical and Electrical Equipment**

This section is intended to address only seismic qualification of electrical components and equipment in accordance with USNRC Regulatory Guide 1.70. However, recognizing that dynamic loads due to suppression pool dynamics associated with a loss-of-coolant accident (LOCA) and safety/relief valve (SRV) discharge can have a significant vibratory effect on the Reactor Building, and, hence, on the design of structures, systems, and equipment in the Reactor Building, equipment qualification for both seismic and other Reactor Building Vibration (RBV) dynamic loads has been addressed in this section. The format utilized is consistent with Regulatory Guide 1.70; thus, reference to the Safe Shutdown Earthquake (SSE) or Operating Basis Earthquake (OBE) in this section includes the combined seismic and other RBV dynamic loads. The non-seismic RBV dynamic loads are described in Table 3.9-2. The specific seismic and dynamic input response spectra will be properly defined and enveloped in the methodology implemented in the equipment qualification program for both units of the Lungmen NPS.

The mechanical components and equipment and the electrical components that are integral to the mechanical equipment are dynamically qualified as described in Section 3.9.

Principal Seismic Category I structures, systems and components are identified in Table 3.2-1. Most of these items are safety-related as explained in Subsection 3.2.1. The safety-related functions are defined in Section 3.2, and include the functions essential to emergency reactor shutdown, containment isolation, reactor core cooling, reactor protection, containment and reactor heat removal, and emergency power supply, and others which are essential in preventing significant release of radioactive material to the environment.

#### **3.10.1 Seismic Qualification Criteria (Including Other Dynamic Loads)**

##### **3.10.1.1 Selection of Qualification Method**

Dynamic qualification of Seismic Category I instrumentation and electrical equipment is accomplished by test, analysis, or a combination of the two methods.

Qualification by analysis alone, without testing, is acceptable only if the necessary functional operability of the equipment is assured by its structural integrity alone. When complete testing is impractical, a combination of test and analysis is acceptable.

In general, analysis is used to supplement test data, although simple components may lend themselves to dynamic analysis in lieu of full-scale testing. The deciding factors for choosing between tests or analysis include:

- (1) The magnitude and frequency of seismic and other RBV dynamic loadings.

- (2) The environmental conditions (Subsection 3.11.1) associated with the dynamic loadings.
- (3) The nature of the safety-related function(s).
- (4) The size and complexity of the equipment.
- (5) The dynamic characteristics of expected failure modes (structural or functional).
- (6) The partial test data upon which to base the analysis.
- (7) The dynamic coupling between equipment and related systems, if any, such as connected piping and other mechanical components.

The selection of qualification methods to be used is largely a matter of engineering judgement; however, tests, and/or analyses of assemblies are preferable to tests or analyses on separate components (e.g., a motor and a pump, including the coupling and other appurtenances should be tested or analyzed as an assembly).

### **3.10.1.2 Input Motion**

The input motion for the qualification of equipment and supports is defined by response spectra. The required response spectra (RRS) are generated from the dynamic analysis of the buildings, as described in Section 3.7. They are grouped by buildings and by elevations. This RRS definition incorporates the contribution and other RBV dynamic loads as specified by the load combination Table 3.9-2. When one type of equipment is located at several elevations and/or in several buildings, the governing response spectra are specified.

### **3.10.1.3 Dynamic Qualification Program**

The dynamic qualification program is described in Section 4.4 of GE's Environmental Qualification Program, which is referenced in Subsection 3.11.2. The program conforms to the requirements of IEEE-323 as modified and endorsed by the Regulatory Guide 1.89, and meets the criteria contained in IEEE-344 as modified and endorsed by Regulatory Guide 1.100.

## **3.10.2 Methods and Procedures for Qualifying Electrical Equipment and Instrumentation**

The following subsections describe the methods and procedures incorporated in the above mentioned dynamic qualification program. Described here are the general methods and procedures to qualify by test or analysis Seismic Category I instrumentation and electrical equipment for operability during and after an SSE including other RBV dynamic loads and to ensure structural and functional integrity of the equipment after an OBE including other RBV dynamic loads.

### **3.10.2.1 Qualification by Testing**

The testing methodology for Seismic Category I instrumentation and electrical equipment includes the hardware interface requirements and the test methods. The methodology for qualifying relays shall be such that testing is performed in both the open and closed positions.

#### **3.10.2.1.1 Interface Requirements**

Intervening structure or components (such as interconnecting cables, bus ducts, conduits, etc.) that serve as interfaces between the equipment to be qualified and that supplied by others are not qualified as part of this program. However, the effects of interfacing are taken into consideration. When applicable, accelerations and frequency content at locations of interfaces with interconnecting cables, bus ducts, conduits, etc., are determined and documented in the test report. This information is specified in the form of interface criteria.

To minimize the effects of interfaces on the equipment, standard configurations using bottom cable entry are utilized whenever possible. Where non-rigid interfaces are located at the equipment support top, equipment qualification is based on the top entry requirements. A report, including equipment support outline drawings, is furnished specifying the equipment maximum displacement during an SSE including other RBV dynamic loads. Embedment loads and mounting requirements for the equipment supports are also specified in this manner.

#### **3.10.2.1.2 Test Methods**

The test method is multi-axial, random single- and/or multi-frequency excitation to envelope generic RRS levels in accordance with Sections 6.6.3 and 6.6.6 of IEEE-344. Past testing has demonstrated that Seismic Category I instrumentation and electrical equipment have critical damping ratios equal to or less than 5%. Hence, RRS at 5% or less critical damping ratio are developed as input to the equipment base.

Multi-axial testing applies input motions to both the vertical and one or both horizontal axes simultaneously. Independent random inputs are preferred and, when used, the test is performed in two steps with equipment rotated 90 degrees in the horizontal plane in the second step.

When independent random tests are not available, four tests are performed:

- (1) With the inputs in phase
- (2) With one input 180 degrees out of phase
- (3) With the equipment rotated 90 degrees horizontally and the inputs in phase
- (4) With the same orientation as in the step (3) but with one input 180 degrees out of phase

**3.10.2.1.2.1 Selection of Test Specimen**

Representative samples of equipment and supports are selected for use as test specimens. Variations in the configuration of the equipment are analyzed with supporting test data. For example, these variations may include mass distributions that differ from one cabinet to another. From test or analysis, it is determined which mass distribution results in the maximum acceleration and/or frequency content, and this worst-case configuration is used as the test specimen. The test report includes a justification that this configuration envelops all other equipment configurations.

**3.10.2.1.2.2 Mounting of Test Specimen**

The test specimen is mounted to the test table so that inservice mounting, including interfaces, is simulated.

For interfaces that cannot be simulated on the test table, the acceleration and any resonances at such interface locations are recorded during the equipment test and documented in the test report.

**3.10.2.1.3 Dynamic Testing Sequence**

The test sequence includes vibration conditioning, exploratory resonance search, the OBE and SSE, including the associated other RBV dynamic loads, respectively.

**3.10.2.1.3.1 Vibration Conditioning**

If required by Paragraph 4.4.2.4.5 of Reference 3.11-2 in Section 3.11, vibration aging program, vibration conditioning is performed at this point in the sequence and the vibration conditioning details are given.

**3.10.2.1.3.2 Exploratory Tests**

Exploratory tests are sine-sweep tests to determine resonant frequency and transmission factors at locations of Seismic Category I devices in the instrument panel. The exploratory tests are run at an acceleration level of 0.2g, which is intended to excite all modes between 1 and 60 Hz and at a sweep rate of 2 octaves per minute or less. This acceleration level is chosen to provide a usable signal-to-noise ratio for the sensing equipment to allow accurate detection of natural test frequencies of the test specimens.

These tests are run for one axis at a time in three mutually perpendicular major axes corresponding to the side-to-side, front-to-back, and vertical directions.

**3.10.2.1.3.3 SSE and OBE Testing Including Other RBV Dynamic Loads**

SSE and OBE testing, including other appropriate RBV dynamic loads, is performed on all test specimens. This test is conducted to demonstrate that neither the SSE nor OBE (as defined in Section 3.7) combined with other RBV dynamic loads will not prevent the equipment from

performing its safety-related functions. The test inputs are applied for a minimum of 15 seconds in each orientation. Operability of equipment is verified as described in Subsection 3.10.2.1.3.4 using the criteria in Subsection 3.7.3.2.

#### **3.10.2.1.3.4 Qualification for Operability**

In general, analyses are only used to supplement operability test data. However, analyses, without testing, are used as a basis for demonstration of functional capability, if the necessary functional operability of the instrumentation or equipment is assured by its structural integrity alone.

Equipment is tested in an operational condition. Most Seismic Category I instrumentation and electrical equipment have safety-related function requirements before, during, and after seismic events.

Other equipment (such as plant status display equipment) have requirements only before and after seismic events. All equipment is operated at appropriate times to demonstrate ability to perform its safety-related function.

If a malfunction is experienced during any test, the effects of the malfunction are determined and documented in the final test report.

Equipment that has been previously qualified by means of tests and analyses equivalent to those described in this section are acceptable provided proper documentation of such tests and analyses is available.

#### **3.10.2.1.4 Final Test Report**

The final test report contains a summary of test/analysis results, which is readily available for audit. The report normally includes but is not limited to the following:

- (1) Locations of accelerometers,
- (2) Resonant frequency if any and transmission ratios,
- (3) Calculation of equipment damping coefficient if there is resonance in the, 1–60 Hz range or over the range of the test response spectra,
- (4) Test equipment used,
- (5) Approval signature and dates,
- (6) Description of test facility,
- (7) Summary of results,

- (8) Conclusion as to equipment seismic (including other RBV dynamic loads) qualification, and
- (9) Justification for using single axis or single frequency tests for all items that are tested in this manner.

### **3.10.2.2 Qualification by Analysis**

The discussions presented in the following subsections apply to the qualification of equipment by analysis.

#### **3.10.2.2.1 Analysis Methods**

Dynamic analysis or an equivalent static analysis is employed to qualify the equipment. In general, the choice of the analysis is based on the expected design margin, since the static coefficient method (the easiest to perform) is far more conservative than the dynamic analysis method.

If the fundamental frequency of the equipment is above the input excitation frequency, the equipment is considered rigid. In this case, the loads on each component can be determined statically by concentrating its mass at its center of gravity and multiplying the values of the mass with the appropriate maximum floor acceleration (i.e., floor spectra acceleration at the high frequency asymptote of the RRS) at the equipment support point.

A static coefficient analysis may be also used for certain equipment in lieu of the dynamic analysis. No determination of natural frequencies is made in this case. The dynamic loads are determined statically by multiplying the actual distributed weight of the equipment by a static coefficient equal to 1.5 times the peak value of the RRS at the equipment mounting location.

This method is only applicable to equipment with simple frame-type structures and can be represented by a simple model. For equipment having configuration other than simple frame-type structure, this method may be applied when justification can be provided for the static factor which is used on a case-by-case basis.

If the equipment is determined to be flexible (i.e., within the frequency range of the input spectra) and not simple enough for equivalent static analysis, a dynamic analysis method is applied. Dynamic analysis by the response spectrum method is outlined in Subsection 3.7.2.1.3.

#### **3.10.2.2.2 Analysis for SSE and OBE Including Other RBV Dynamic Loads**

An analysis is performed for SSE and OBE (including appropriate other RBV dynamic loads) in accordance with the criteria in Subsection 3.7.3.2. The analysis must show that following an OBE, including appropriate other RBV dynamic loads, the structural integrity of the equipment is maintained. The analysis must show that following such an SSE, including appropriate other RBV dynamic loads, failure of the equipment to perform its safety-related function(s) does not result.

### **3.10.2.2.3 Documentation of Analysis**

The demonstration of qualification is documented, including the requirements of the equipment specification, the results of the qualification, and the justification that the methods used are capable of demonstrating that the equipment will not malfunction.

### **3.10.2.3 Qualification by Combined Testing and Analysis**

In some instances, it is not practical to qualify Seismic Category I instrumentation and electrical equipment solely by testing or analysis. This may be because of the size of the equipment, its complexity, or the large number of similar configurations. The following subsections address the cases in which combined analysis and testing may be warranted.

#### **3.10.2.3.1 Low Impedance Excitation**

Large equipment may be impractical to test due to limitations in vibration equipment loading capability. With the equipment mounted to simulate service mounting, a number of exciters are attached at points which will best excite the various modes of vibration of the equipment. Data is obtained from sensors for subsequent analysis of the equipment performance under seismic plus other RBV dynamic loads. The amplification of resonant motion is used to determine the appropriate modal frequency and damping for a dynamic analysis of the equipment.

This method can be used to qualify the equipment by exciting the equipment to levels at least equal to the expected response from an earthquake, including other RBV dynamic loads, using analysis to justify the excitation or utilization of the test data on modal frequencies in a mathematical model to verify performance.

#### **3.10.2.3.2 Extrapolation of Similar Equipment**

As discussed in IEEE-344, the qualification of complex equipment by analysis is not recommended because of the great difficulty in developing an accurate analytical model.

In many instances, however, similar equipment has already been qualified but with changes in size or in specific qualified devices in a fixed assembly or structure. In such instances, a full test program (Subsection 3.10.2.1) is conducted on a typical piece of equipment. A single frequency test is used in addition to any multi-frequency test.

If the equipment is not rigid, the effects of the changes are analyzed. The test results, combined with the analysis, allow the model of the similar equipment to be adjusted to produce a revised stiffness matrix and to allow refinement of the analysis for the modal frequencies of the similar equipment. The result is a verified analytical model that is used to qualify the similar equipment.

### **3.10.2.3.3 Extrapolation of Dynamic Loading Conditions**

Test results can be extrapolated for dynamic loading conditions in excess of or different from previous tests are given on a piece of equipment when the test results are in sufficient detail to allow an adequate dynamic model of the equipment to be generated. The model provides the capability of predicting failure under the increased or different dynamic load excitation.

### **3.10.3 Methods and Procedures of Analysis or Testing of Supports of Electrical Equipment and Instrumentation**

The following subsections describe the general methods and procedures, as incorporated in the dynamic qualification program (Subsection 3.10.1.3), for analysis and testing of supports of Seismic Category I instrumentation and electrical equipment. When possible, the supports of most of the electrical equipment (other than motor and valve-mounted equipment supports, mostly control panels and racks) in the nuclear steam supply systems (NSSS) are tested with the equipment installed. Otherwise, a dummy is employed to simulate inertial mass effect and dynamic coupling to the support.

Combined stresses of the mechanically designed component supports are maintained within the limits of ASME Code Section III, Division 1, Subsection NF, up to the interface with the building structure; and the combined stresses of the structurally designed component supports defined as building structure in the project design specifications are maintained within the limits of the AISC Specification for the Design, Fabrication and Erection of Structural Steel for Buildings.

#### **3.10.3.1 NSSS Electrical Equipment Supports (Other Than Motors and Valve-Mounted Equipment)**

The seismic and other RBV dynamic load qualification tests on equipment supports are performed over the frequency range of interest.

Some of the Seismic Category I supports are qualified by analysis only. Analysis is used for passive mechanical devices and is sometimes used in combination with testing for larger assemblies containing Seismic Category I devices. For instance, a test is run to determine if there are natural frequencies in the support equipment within the critical frequency range. If the support is determined to be free of natural frequencies (in the critical frequency range), then it is assumed to be rigid and a static analysis is performed. If natural frequencies are present in the critical frequency range, then calculations of transmissibility and responses to varying input accelerations are determined to see if Seismic Category I devices mounted in the assembly would operate without malfunctioning. In general, the testing of Category I supports is accomplished using the following procedure:

Assemblies (e.g., control panels) containing devices which have dynamic load malfunction limits established are tested by mounting the assembly on the table of a vibration machine in the manner it is to be mounted when in use and vibration testing it by running a low-level

resonance search. As with the devices, the assemblies are tested in the three major orthogonal axes.

The resonance search is run in the same manner as described for devices. If resonances are present, the transmissibility between the input and the location of each device is determined by measuring the accelerations at each device location and calculating the magnification between it and the input. Once known, the transmissibilities could be used analytically to determine the response at any Seismic Category I device location for any given input. (It is assumed that the transmissibilities are linear as a function of acceleration even though they actually decrease as acceleration increases; therefore, it is a conservative assumption.)

As long as the device input accelerations are determined to be below their malfunction limits, the assembly is considered a rigid body with a transmissibility equal to one so that a device mounted on it would be limited directly by the assembly input acceleration.

Control panels and racks constitute the majority of Seismic Category I electrical assemblies. There are basically four generic panel types. One or more of each type are tested using these procedures. Figures 3.10-1 through 3.10-4 illustrate the four basic panel types and show typical accelerometer locations.

From these full acceleration level tests, it will be concluded that most of the panel types have more than adequate structural strength and that a given panel design acceptability is just a function of its amplification factor and the malfunction levels of the devices mounted in it.

Subsequent panels are, therefore, tested at lower acceleration levels and the transmissibilities measured to the various devices as described. By dividing the devices' malfunction levels by the panel transmissibility between the device and the panel input, the panel dynamic qualification level could be determined. Several high level tests will be run on selected generic panel designs to assure the conservativeness in using the transmissibility analysis described.

### **3.10.3.2 Other Seismic Category I Instrumentation and Electrical Equipment Supports**

#### **3.10.3.2.1 Supports for Battery Racks, Instrument Racks, Control Consoles, Cabinets, and Panels**

Response spectra are specified for floors where Seismic Category I equipment is located. Test data, operating experience, and/or calculations will be provided to verify that the equipment will not suffer any loss of function before, during, or after the specified dynamic disturbance. Analysis and/or testing procedures are in accordance with Subsection 3.10.2.

In essence, these supports are inseparable from their supported items and are qualified with the items. During testing, the supports are fastened to the test table with fastening devices or methods used in the actual installation, thereby qualifying the total installation.

**3.10.3.2.2 Local Instrument Supports**

For field-mounted Seismic Category I instruments, the following is applicable:

- (1) The mounting structures for the instruments have a fundamental frequency above the excitation frequency of the RRS.
- (2) The stress level in the mounting structure does not exceed the material allowable stress when the mounting structure is subjected to the maximum acceleration level for its location.

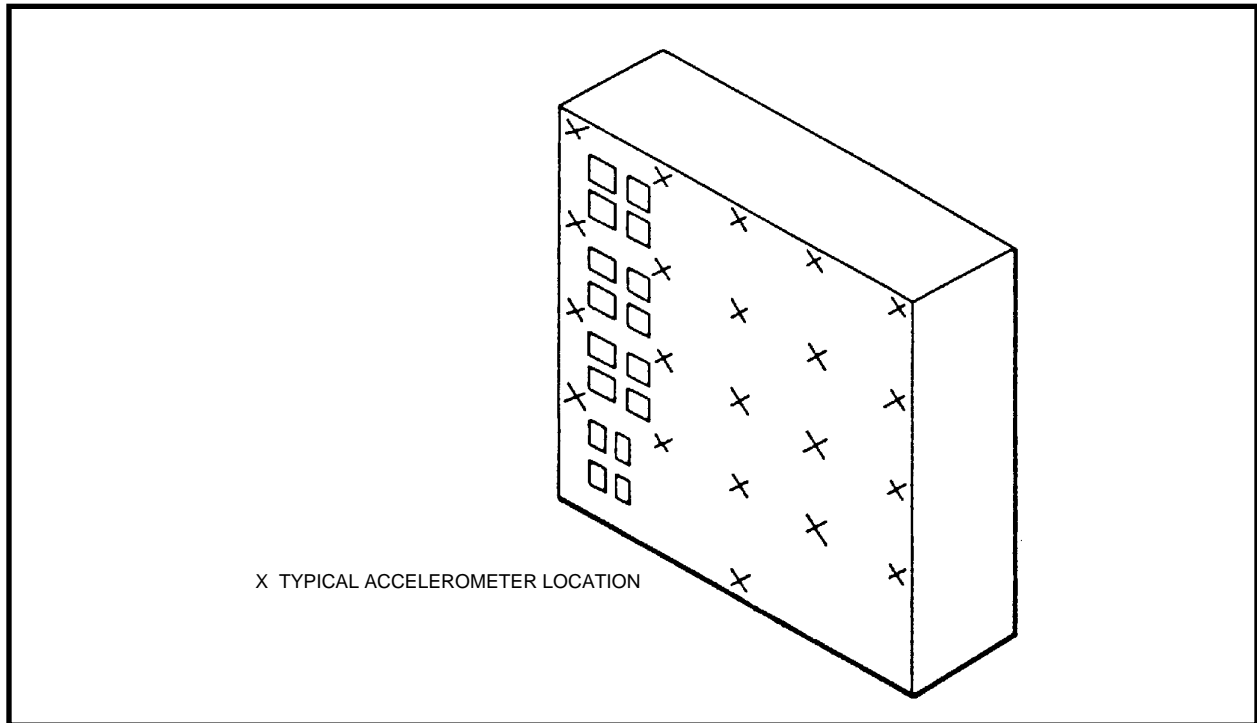

**Figure 3.10-1 Typical Vertical Board**

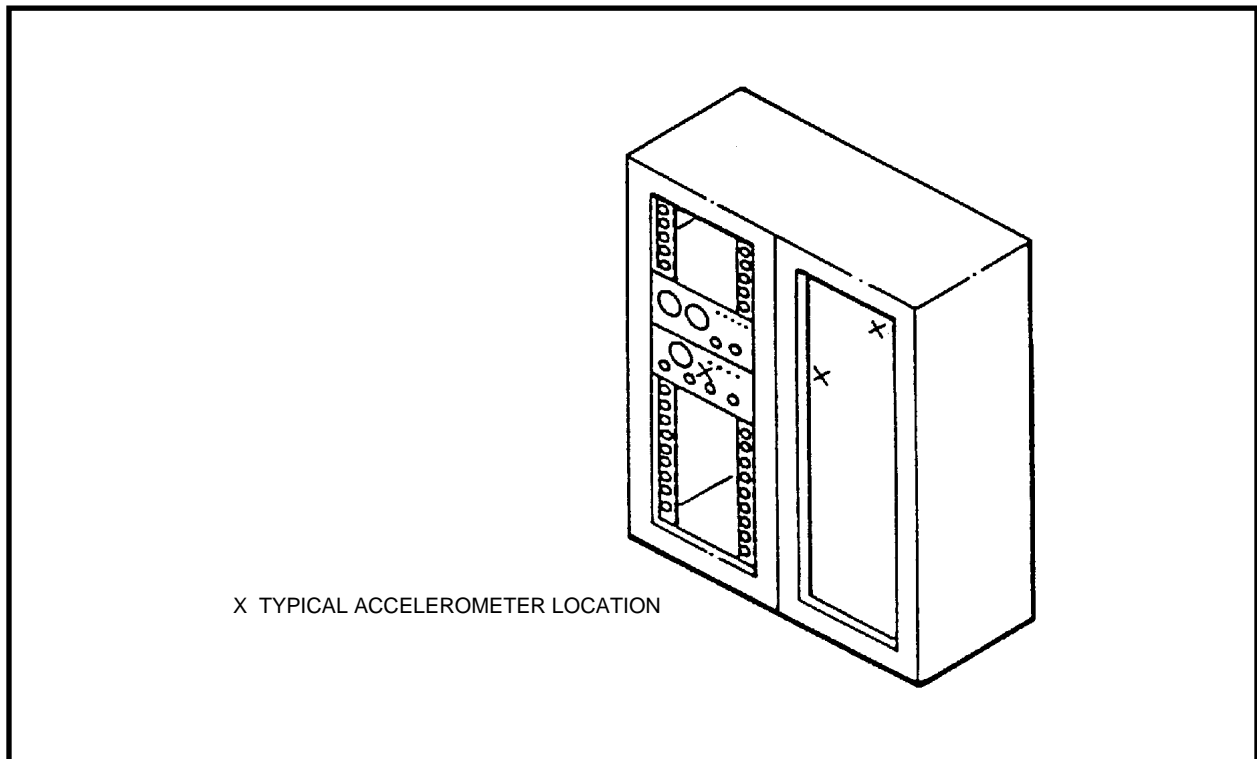

**Figure 3.10-2 Instrument Panel**

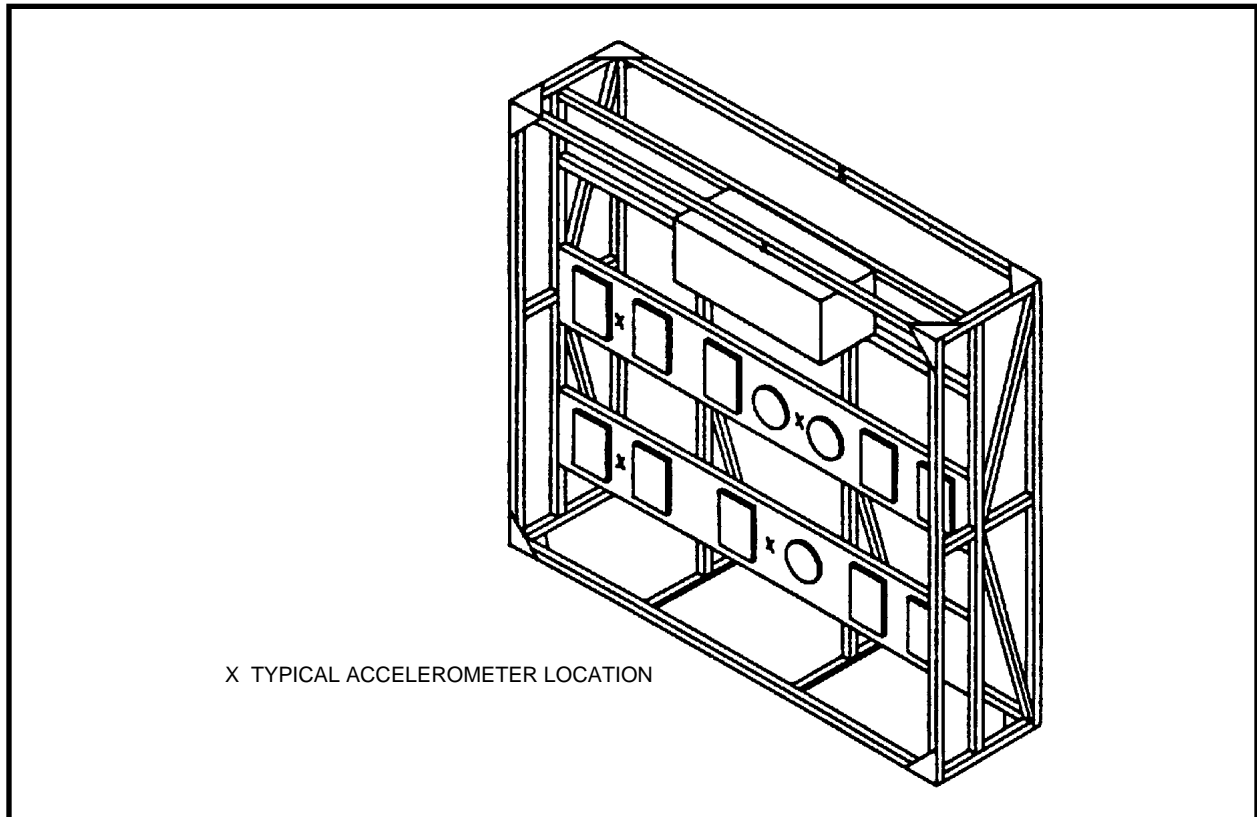

**Figure 3.10-3 Typical Local Rack**

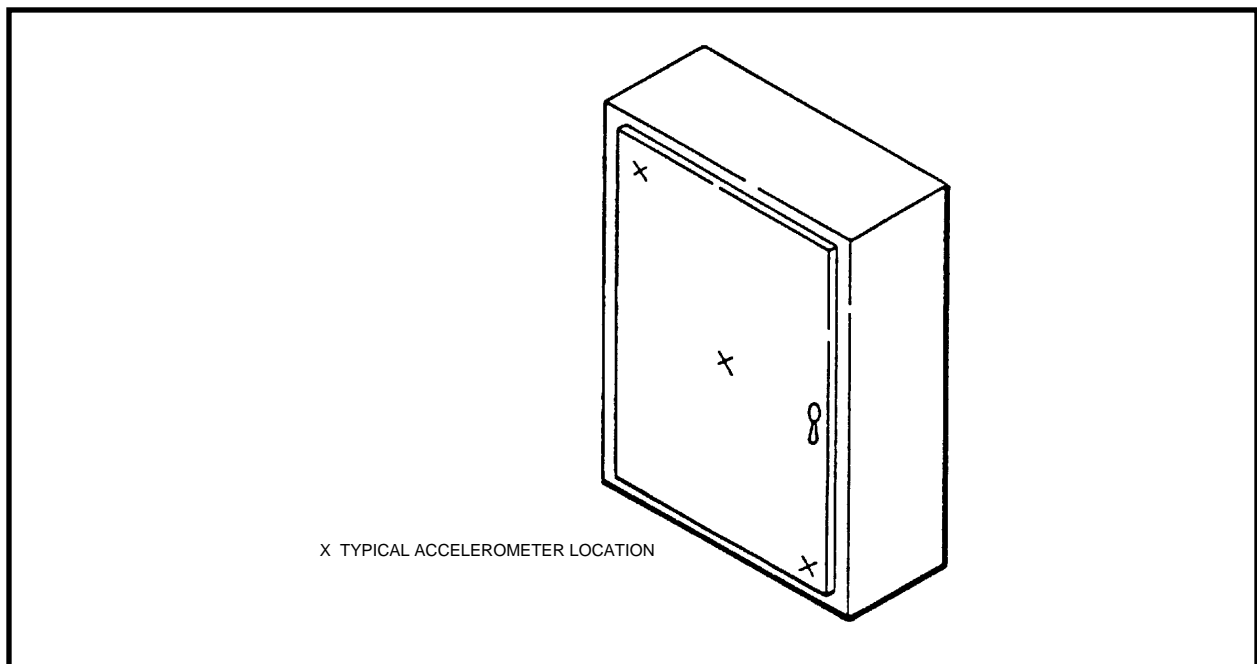

**Figure 3.10-4 NEMA Type-12 Enclosure**